



**PPT ON
ELECTRICAL MACHINES – II
IV SEM (IARE-R18)**



MODULE - I

PULSATING AND REVOLVING

MAGNETIC FIELDS

Rotating Magnetic Field

- Balanced three phase windings, i.e. mechanically displaced 120 degrees from each other, fed by balanced three phase source
- A rotating magnetic field with constant magnitude is produced, rotating with a speed

$$n_{sync} = \frac{120f_e}{P} \text{ rpm}$$

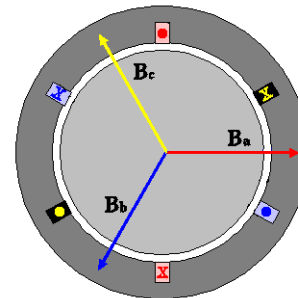

- Where f_e is the supply frequency and P is the no. of poles and n_{sync} is called the synchronous speed in *rpm* (revolutions per minute)
- Synchronous speed:

P	50 Hz	60 Hz
2	3000	3600
4	1500	1800
6	1000	1200
8	750	900

Contd..



$$B_{net}(t) = B_a(t) + B_b(t) + B_c(t)$$

$$= B_M \sin(\omega t) \angle 0^\circ + B_M \sin(\omega t - 120^\circ) \angle 120^\circ + B_M \sin(\omega t - 240^\circ) \angle 240^\circ$$

$$= B_M \sin(\omega t) \hat{x}$$

$$- [0.5 B_M \sin(\omega t - 120^\circ)] \hat{x} - \left[\frac{\sqrt{3}}{2} B_M \sin(\omega t - 120^\circ) \right] \hat{y}$$

$$- [0.5 B_M \sin(\omega t - 240^\circ)] \hat{x} + \left[\frac{\sqrt{3}}{2} B_M \sin(\omega t - 240^\circ) \right] \hat{y}$$

$$B_{net}(t) = \left[B_M \sin(\omega t) + \frac{1}{4} B_M \sin(\omega t) + \frac{\sqrt{3}}{4} B_M \cos(\omega t) + \frac{1}{4} B_M \sin(\omega t) - \frac{\sqrt{3}}{4} B_M \cos(\omega t) \right] \hat{x}$$

$$+ \left[-\frac{\sqrt{3}}{4} B_M \sin(\omega t) - \frac{3}{4} B_M \cos(\omega t) + \frac{\sqrt{3}}{4} B_M \sin(\omega t) - \frac{3}{4} B_M \cos(\omega t) \right] \hat{y}$$

$$= [1.5 B_M \sin(\omega t)] \hat{x} - [1.5 B_M \cos(\omega t)] \hat{y}$$

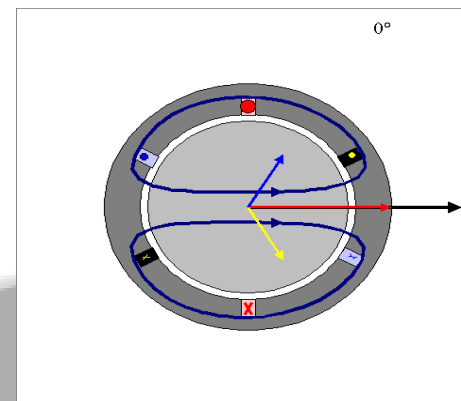
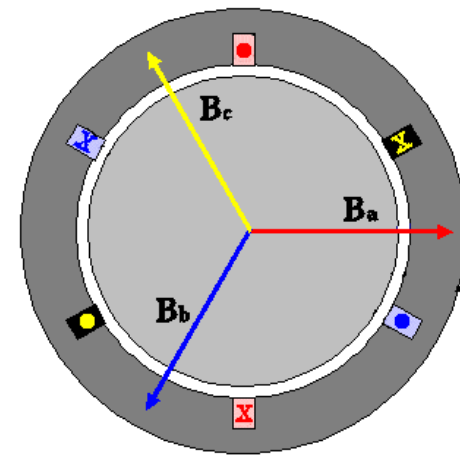



MODULE - II

INDUCTION MACHINES

Construction

- An induction motor has two main parts
- **stator**
 - consisting of a steel frame that supports a hollow, cylindrical core
 - core, constructed from stacked laminations (why?), having a number of evenly spaced slots, providing the space for the stator winding

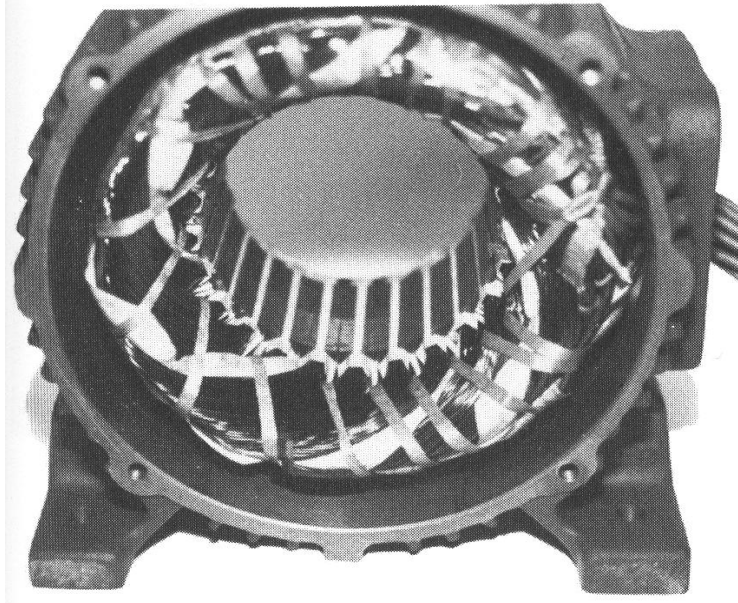

Rotor

- composed of punched laminations, stacked to create a series of rotor slots, providing space for the rotor winding
- one of two types of rotor windings
- conventional 3-phase windings made of insulated wire (wound-rotor) » similar to the winding on the stator
- aluminum bus bars shorted together at the ends by two aluminum rings, forming a squirrel-cage shaped circuit (squirrel-cage)
- Two basic design types depending on the rotor design
 - squirrel-cage: conducting bars laid into slots and shorted at both ends by shorting rings.
 - wound-rotor: complete set of three-phase windings exactly as the stator. Usually Y-connected, the ends of the three rotor wires are connected to 3 slip rings on the rotor shaft. In this way, the rotor circuit is accessible

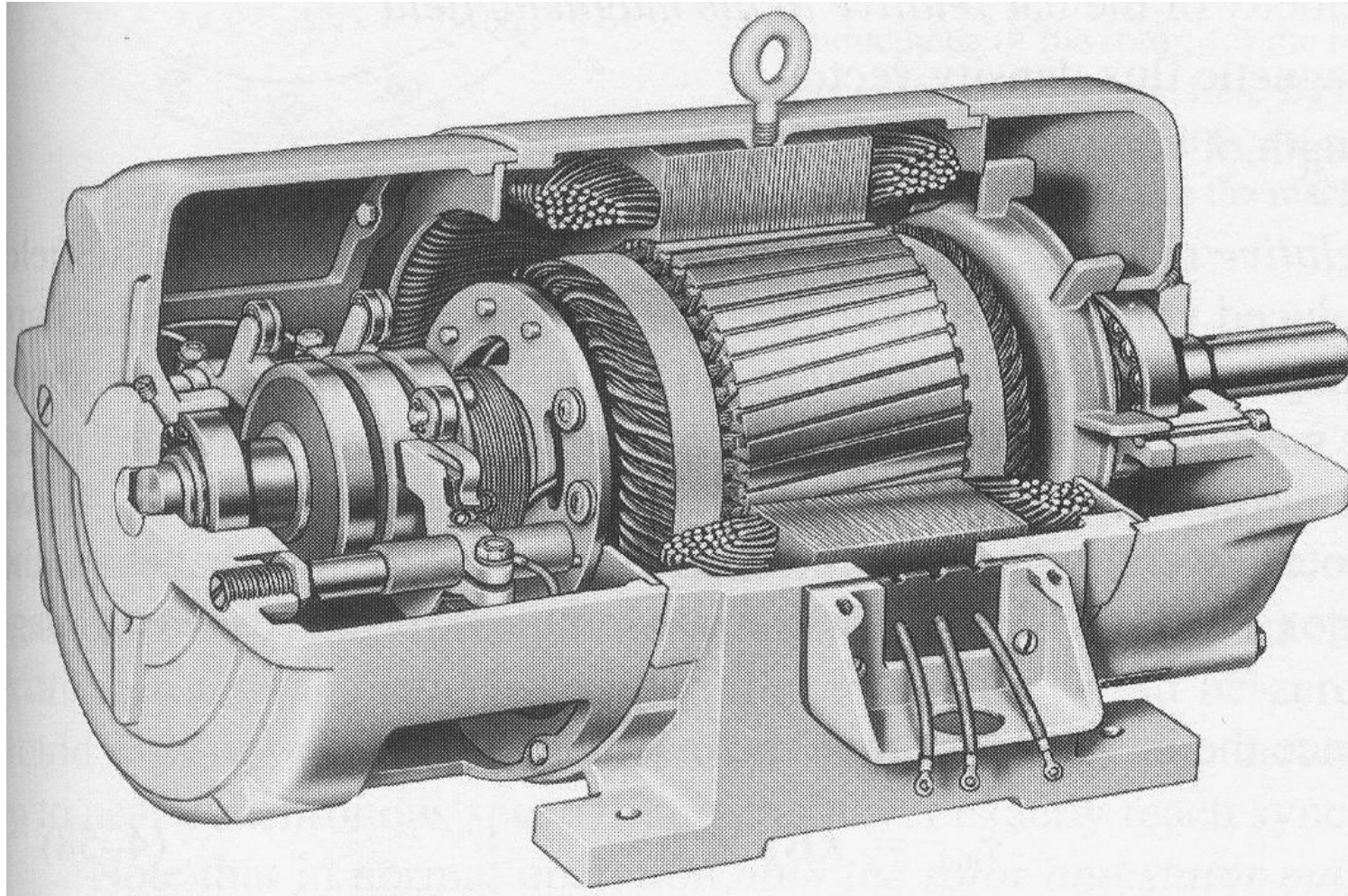

Cage and Wound rotor

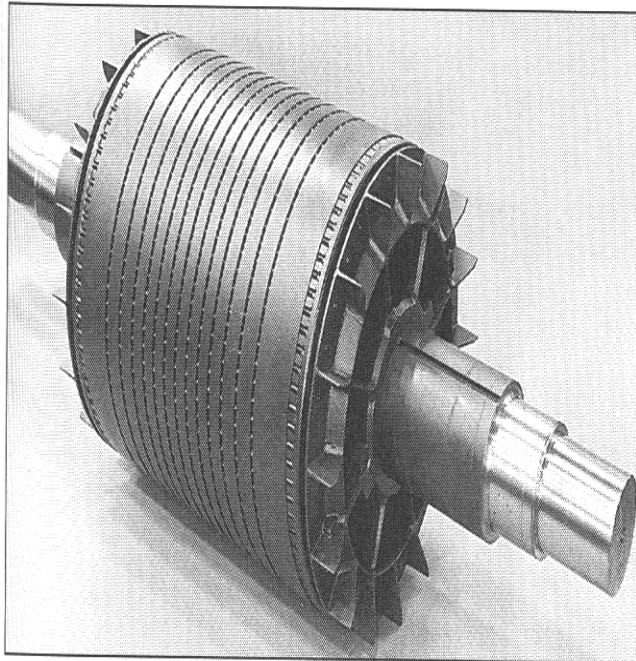

Squirrel cage rotor

Wound rotor

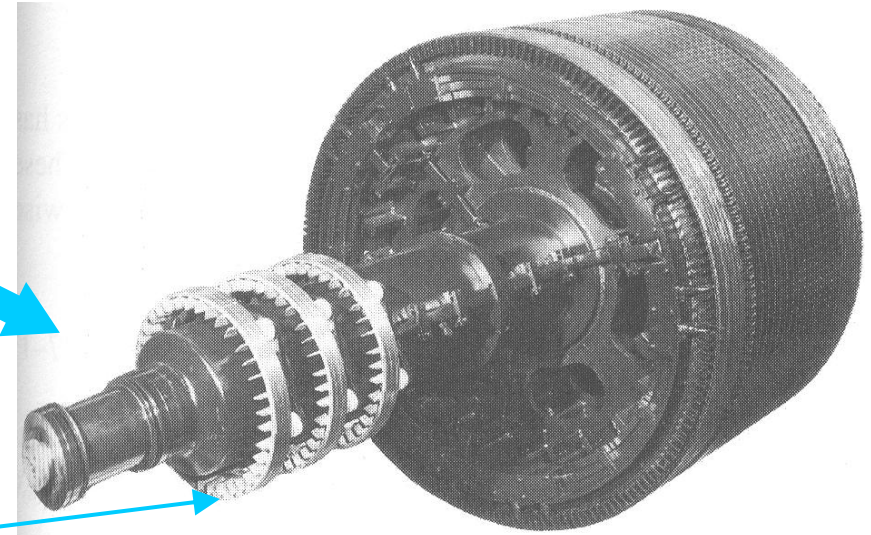

Notice the slip rings

Principle of operation

- This rotating magnetic field cuts the rotor windings and produces an induced voltage in the rotor windings
- Due to the fact that the rotor windings are short circuited, for both squirrel cage and wound-rotor, and induced current flows in the rotor windings
- The rotor current produces another magnetic field
- A torque is produced as a result of the interaction of those two magnetic fields

$$\tau_{ind} = k B_R \times B_S$$

Where τ_{ind} is the induced torque and B_R and B_S are the magnetic flux densities of the rotor and the stator respectively

Induction motor speed

- At what speed will the IM run?
- Can the IM run at the synchronous speed, why?
- If rotor runs at the synchronous speed, which is the same speed of the rotating magnetic field, then the rotor will appear stationary to the rotating magnetic field and the rotating magnetic field will not cut the rotor. So, no induced current will flow in the rotor and no rotor magnetic flux will be produced so no torque is generated and the rotor speed will fall below the synchronous speed
- When the speed falls, the rotating magnetic field will cut the rotor windings and a torque is produced

- So, the IM will always run at a speed lower than the synchronous speed
- The difference between the motor speed and the synchronous speed is called the Slip

$$n_{slip} \equiv n_{sync} - n_m$$

Where n_{slip} = slip speed

n_{sync} = speed of the magnetic field

n_m = mechanical shaft speed of the motor

$$s = \frac{n_{sync} - n_m}{n_{sync}}$$

Where s is the *slip*

Notice that : if the rotor runs at synchronous speed

$$s = 0$$

if the rotor is stationary

$$s = 1$$

Slip may be expressed as a percentage by multiplying the above eq. by 100, notice that the slip is a ratio and doesn't have units

Rotor Frequency

- The frequency of the voltage induced in the rotor is given by

$$f_r = \frac{P \times n}{120}$$

Where f_r = the rotor frequency (Hz)

P = number of stator poles

n = slip speed (rpm)

$$\begin{aligned} f_r &= \frac{P \times (n_s - n_m)}{120} \\ &= \frac{P \times sn_s}{120} = sf_e \end{aligned}$$

- What would be the frequency of the rotor's induced voltage at any speed n_m ?

$$f_r = s f_e$$

When the rotor is blocked ($s=1$), the frequency of the induced voltage is equal to the supply frequency

On the other hand, if the rotor runs at synchronous speed ($s = 0$), the frequency will be zero

Equivalent Circuit

- The induction motor is similar to the transformer with the exception that its secondary windings are free to rotate

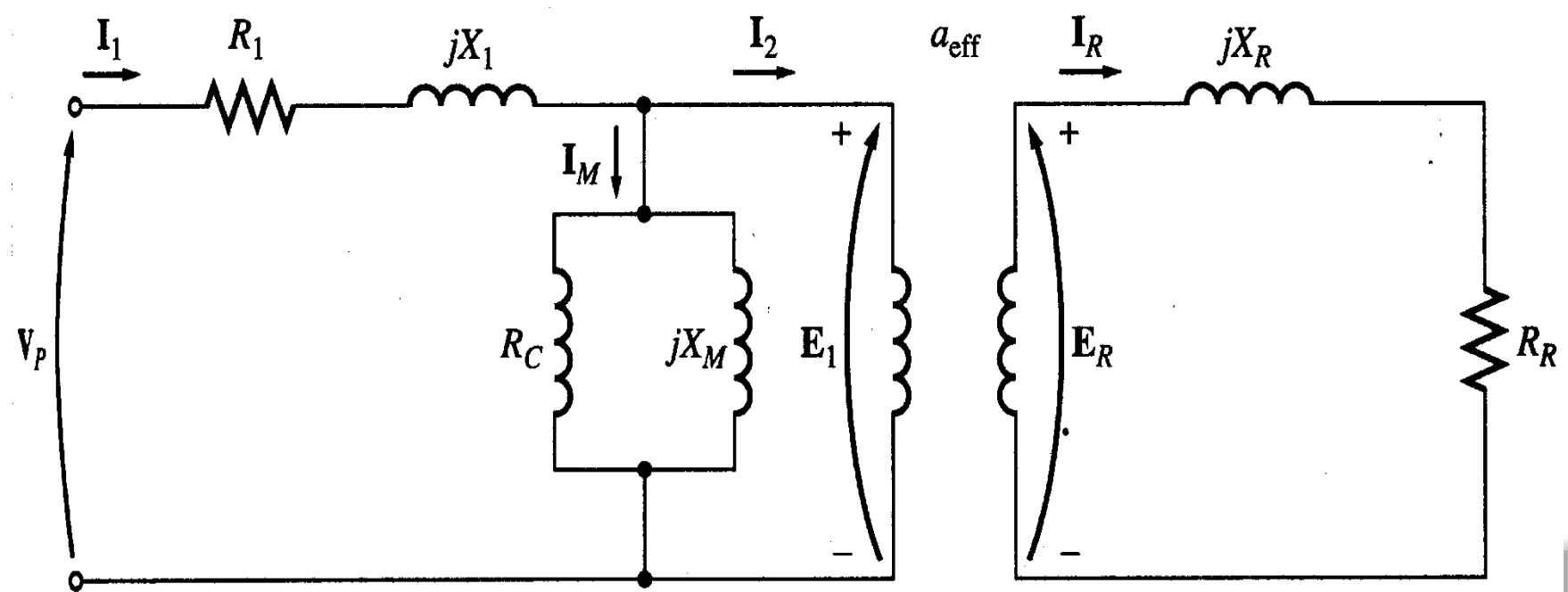

- When the rotor is locked (or blocked), i.e. $s = 1$, the largest voltage and rotor frequency are induced in the rotor, Why?
- On the other side, if the rotor rotates at synchronous speed, i.e. $s = 0$, the induced voltage and frequency in the rotor will be equal to zero, Why?

$$E_R = sE_{R0}$$

Where E_{R0} is the largest value of the rotor's induced voltage obtained at $s = 1$ (locked rotor)

- The same is true for the frequency, i.e.

$$f_r = s f_e$$

It is known that

$$X = \omega L = 2\pi f L$$

So, as the frequency of the induced voltage in the rotor changes, the reactance of the rotor circuit also changes

Where X_{r0} is the rotor reactance at the supply frequency (at blocked rotor)

$$\begin{aligned} X_r &= \omega_r L_r = 2\pi f_r L_r \\ &= 2\pi s f_e L_r \\ &= s X_{r0} \end{aligned}$$

- Then, we can draw the rotor equivalent circuit as follows

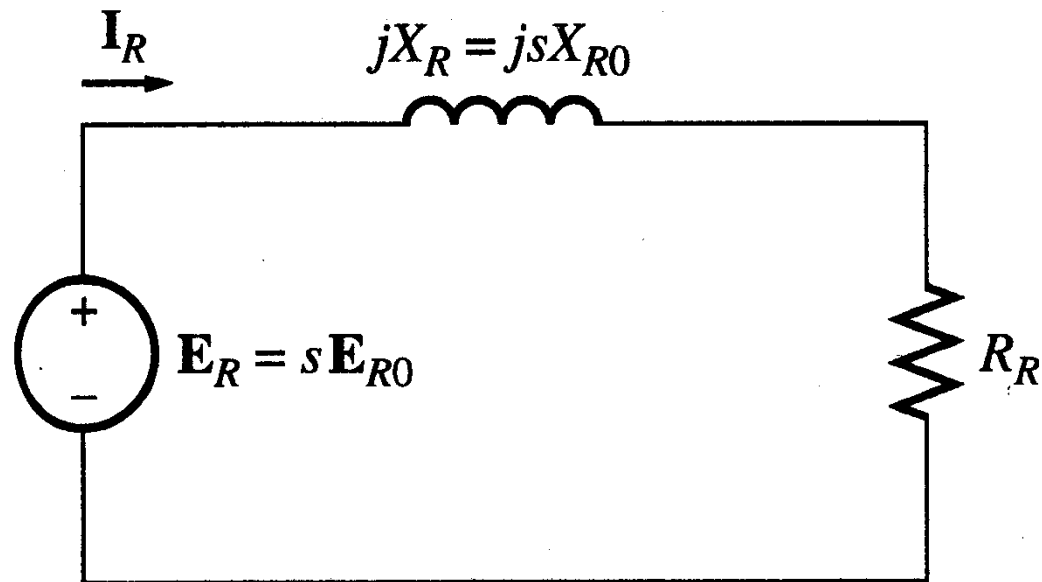

Where E_R is the induced voltage in the rotor and R_R is the rotor resistance

- Now we can calculate the rotor current as

$$\begin{aligned} I_R &= \frac{E_R}{(R_R + jX_R)} \\ &= \frac{sE_{R0}}{(R_R + jsX_{R0})} \end{aligned}$$

Dividing both the numerator and denominator by s so nothing changes we get

$$I_R \equiv \frac{E_{R0}}{\left(\frac{R_R}{s} + jX_{R0}\right)}$$

Where E_{R0} is the induced voltage and X_{R0} is the rotor reactance at blocked rotor condition ($s = 1$)

- Now we can have the rotor equivalent circuit

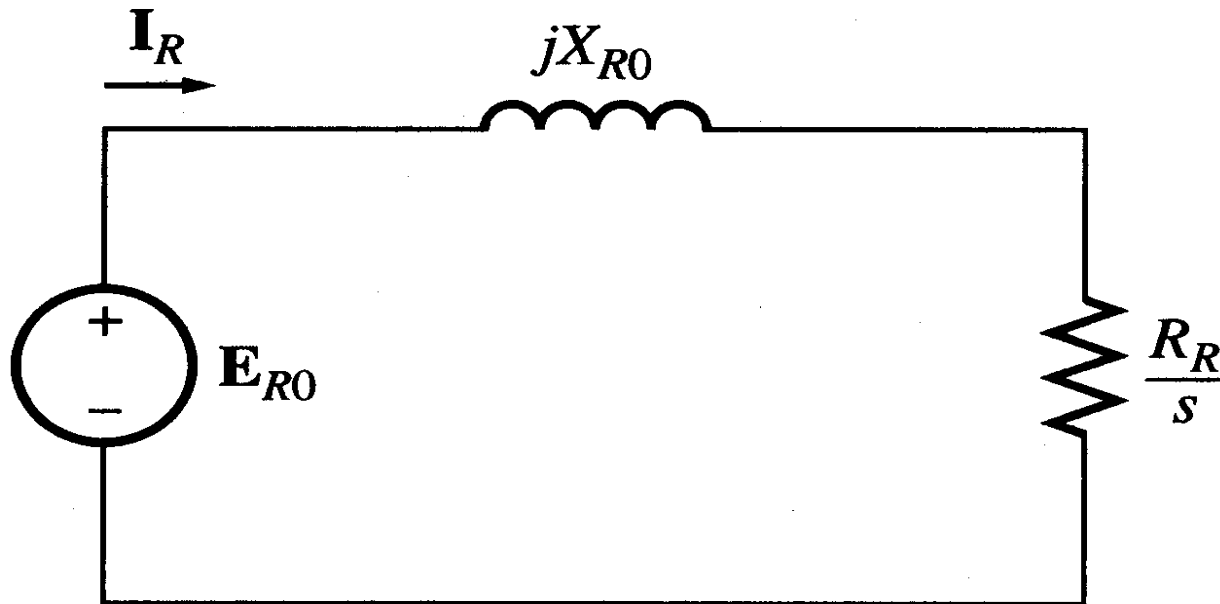

Now as we managed to solve the induced voltage and different frequency problems, we can combine the stator and rotor circuits in one equivalent circuit

- Where

$$X_2 = a_{eff}^2 X_{R0}$$

$$R_2 = a_{eff}^2 R_R$$

$$I_2 = \frac{I_R}{a_{eff}}$$

$$E_1 = a_{eff} E_{R0}$$

$$a_{eff} = \frac{N_S}{N_R}$$

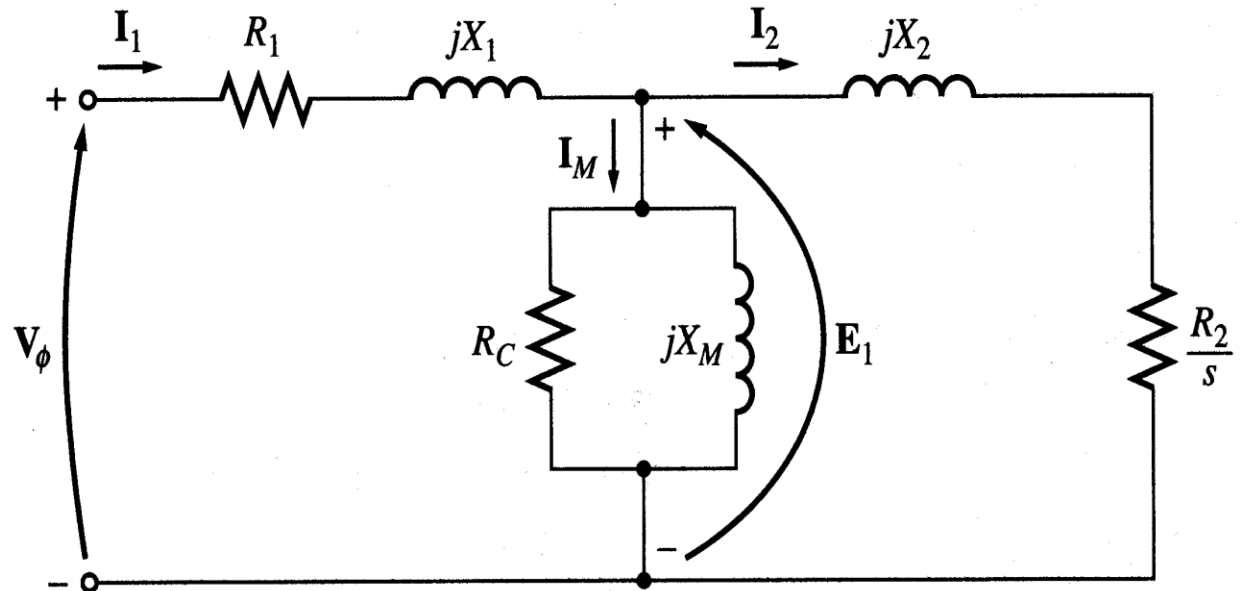

1. The EMF in the stator of an 8 pole induction motor has a frequency of 50 Hz and that in the rotor is 1.5Hz. At what speed the motor is running and what I_{sc} the slip?
2. In case of an 8-pole induction motor the supply frequency was 50 Hz and the shaft speed was 735 rpm. Compute (i) Synchronous speed (ii) Slip speed per unit slip (iii) Percentage slip.

3. An 8 pole, 3phase alternator is coupled to a prime mover running at 750 rpm. It supplies an induction motor which has a full load speed of 960 rpm. Find the number of poles of induction motor and slip.
4. The frequency of stator EMF is 50 Hz for an 8-pole induction motor. If the rotor frequency is 2.5 Hz, calculate the slip and the actual speed of rotor.

Power losses

- Copper losses
- Copper loss in the stator ($P_{SCL} = I_1^2 R_1$)
- Copper loss in the rotor ($P_{RCL} = I_2^2 R_2$)
- Core loss (P_{core})

Mechanical power loss due to friction and windage

How this power flow in the motor?

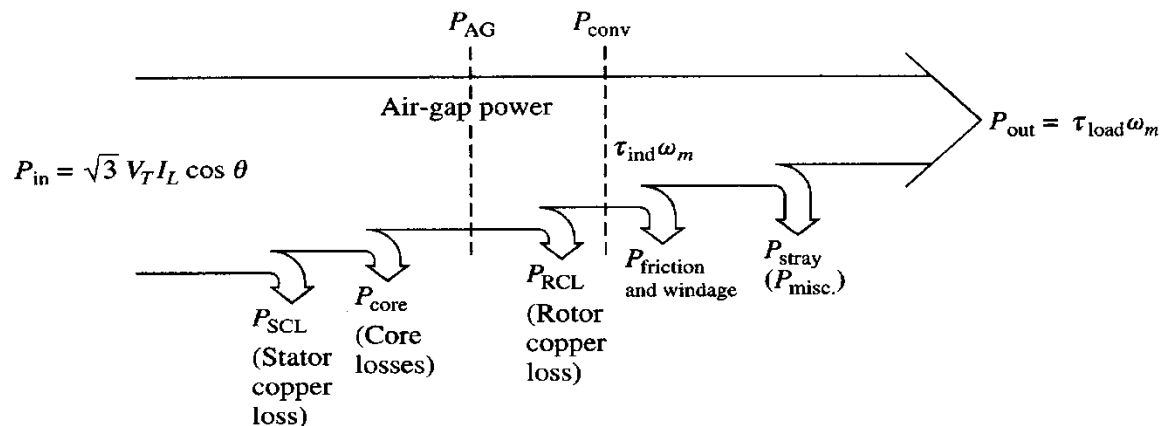

Power relations

$$P_{in} = \sqrt{3} V_L I_L \cos \theta = 3 V_{ph} I_{ph} \cos \theta$$

$$P_{SCL} = 3 I_1^2 R_1$$

$$P_{AG} = P_{in} - (P_{SCL} + P_{core})$$

$$P_{conv} = P_{AG} - P_{RCL}$$

$$\tau_{ind} = \frac{P_{conv}}{\omega_m}$$

$$P_{in} = \sqrt{3} V_L I_L \cos \theta = 3 V_{ph} I_{ph} \cos \theta$$

$$P_{SCL} = 3 I_1^2 R_1$$

$$P_{AG} = P_{in} - (P_{SCL} + P_{core}) = P_{conv} + P_{RCL} = 3 I_2^2 \frac{R_2}{s} = \frac{P_{RCL}}{s}$$

$$P_{RCL} = 3 I_2^2 R_2$$

$$P_{conv} = P_{AG} - P_{RCL} = 3 I_2^2 \frac{R_2 (1-s)}{s} = \frac{P_{RCL} (1-s)}{s}$$

$$P_{conv} = (1-s) P_{AG}$$

$$P_{out} = P_{conv} - (P_{f+w} + P_{stray}) \quad \tau_{ind} = \frac{P_{conv}}{\omega_m} = \frac{(1-s) P_{AG}}{(1-s) \omega_s}$$

Numerical problems

1. The power input to a 500V, 50Hz, 6-pole, 3-phase induction motor running at 975 rpm is 40 KW. The stator losses are 1KW and the friction and wind age losses total to 2KW, Calculate i) The slip ii) Rotor copper loss iii) Shaft power.

2. A 4 pole, 400 V, 3phase IM has a standstill rotor EMF of 100 V per phase. The rotor has resistance of $50 \text{ } \Omega/\text{ph}$ and standstill reactance of $0.5 \text{ } \Omega/\text{ph}$. Calculate the maximum torque & slip at which it occurs. Neglect stator impedance.

3. An 8-pole, 50 Hz, 3 phase slip ring IM has effective resistance of 0.08 Ω /phase the speed corresponding to maximum torque is 650 rpm. What is the value of resistance to be inserted in rotor circuit to obtain maximum torque at starting?
4. 500HP, 30, 440V, 50Hz induction motor has a speed of 950 rpm on full load. The machine has 6 poles. Calculate
- Slip and Speed of rotor field with respect to rotor.
 - Speed of rotor field with respect to stator
 - Complete alternations of rotor voltage per minute.

Relative speed between stator field with respect to rotors

Torque, power and Thevenin's Theorem

- Thevenin's theorem can be used to transform the network to the left of points 'a' and 'b' into an equivalent voltage source V_{TH} in series with equivalent resistance

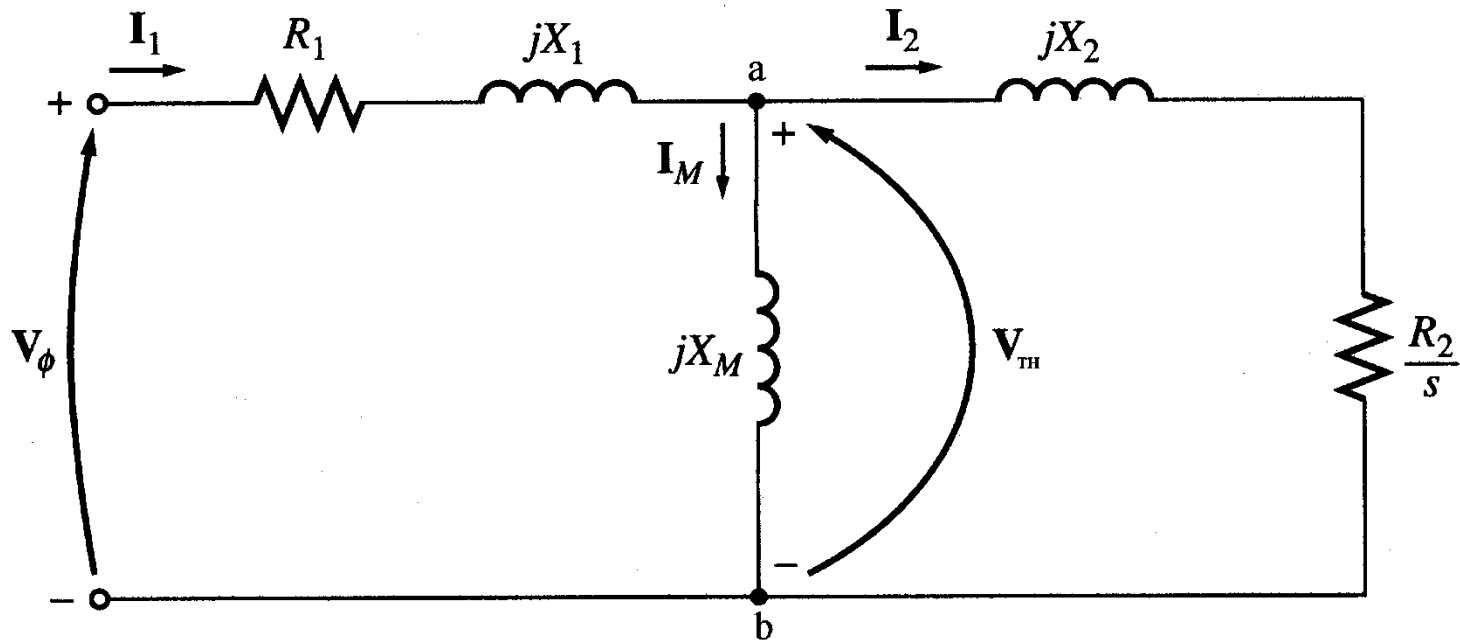

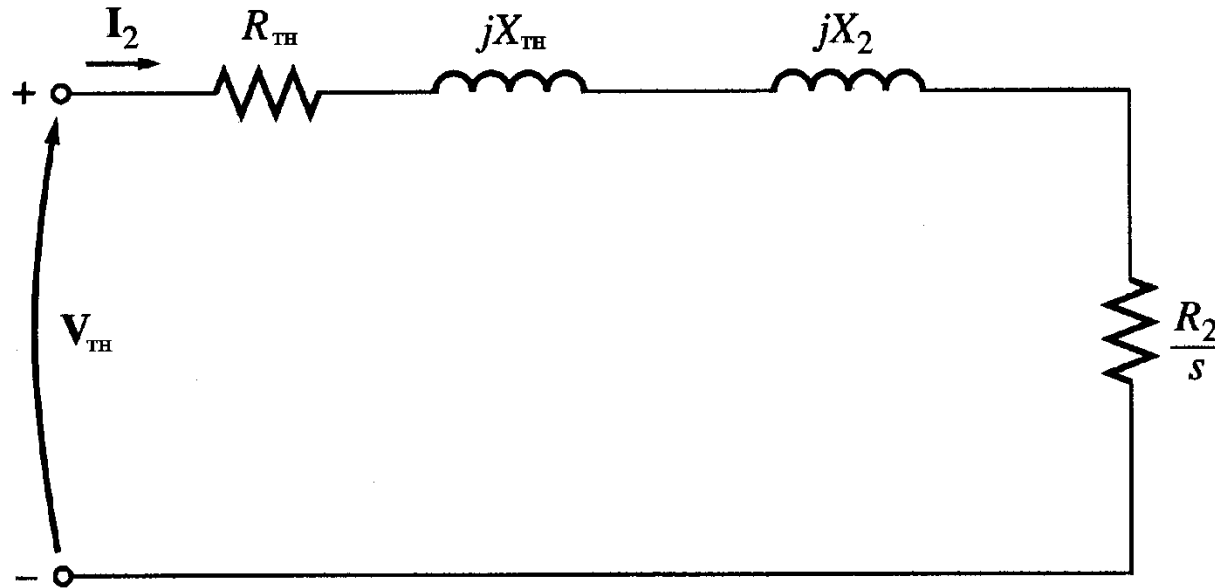

$$V_{TH} = V_{\phi} \frac{jX_M}{R_1 + j(X_1 + X_M)} \quad |V_{TH}| = |V_{\phi}| \frac{X_M}{\sqrt{R_1^2 + (X_1 + X_M)^2}}$$

$$R_{TH} + jX_{TH} = (R_1 + jX_1) // jX_M$$

- Since $X_M \gg X_1$ and $X_M \gg R_1$

$$V_{TH} \approx V_{\phi} \frac{X_M}{X_1 + X_M}$$

Because $X_M \gg X_1$ and $X_M + X_1 \gg R_1$

$$R_{TH} \approx R_1 \left(\frac{X_M}{X_1 + X_M} \right)^2$$
$$X_{TH} \approx X_1$$

$$I_2 = \frac{V_{TH}}{Z_T} = \frac{V_{TH}}{\sqrt{\left(R_{TH} + \frac{R_2}{s}\right)^2 + (X_{TH} + X_2)^2}}$$

Then the power converted to mechanical (P_{conv})

$$P_{conv} = 3I_2^2 \frac{R_2(1-s)}{s}$$

And the internal mechanical torque (T_{conv})

$$\tau_{ind} = \frac{P_{conv}}{\omega_m} = \frac{P_{conv}}{(1-s)\omega_s} = \frac{3I_2^2 \frac{R_2}{s}}{\omega_s} = \frac{P_{AG}}{\omega_s}$$

$$\tau_{ind} = \frac{3}{\omega_s} \left(\frac{V_{TH}}{\sqrt{\left(R_{TH} + \frac{R_2}{s}\right)^2 + (X_{TH} + X_2)^2}} \right)^2 \left(\frac{R_2}{s} \right)$$

$$\tau_{ind} \equiv \frac{1}{\omega_s} \frac{3V_{TH}^2 \left(\frac{R_2}{s} \right)}{\left(R_{TH} + \frac{R_2}{s} \right)^2 + (X_{TH} + X_2)^2}$$

Torque-speed characteristics

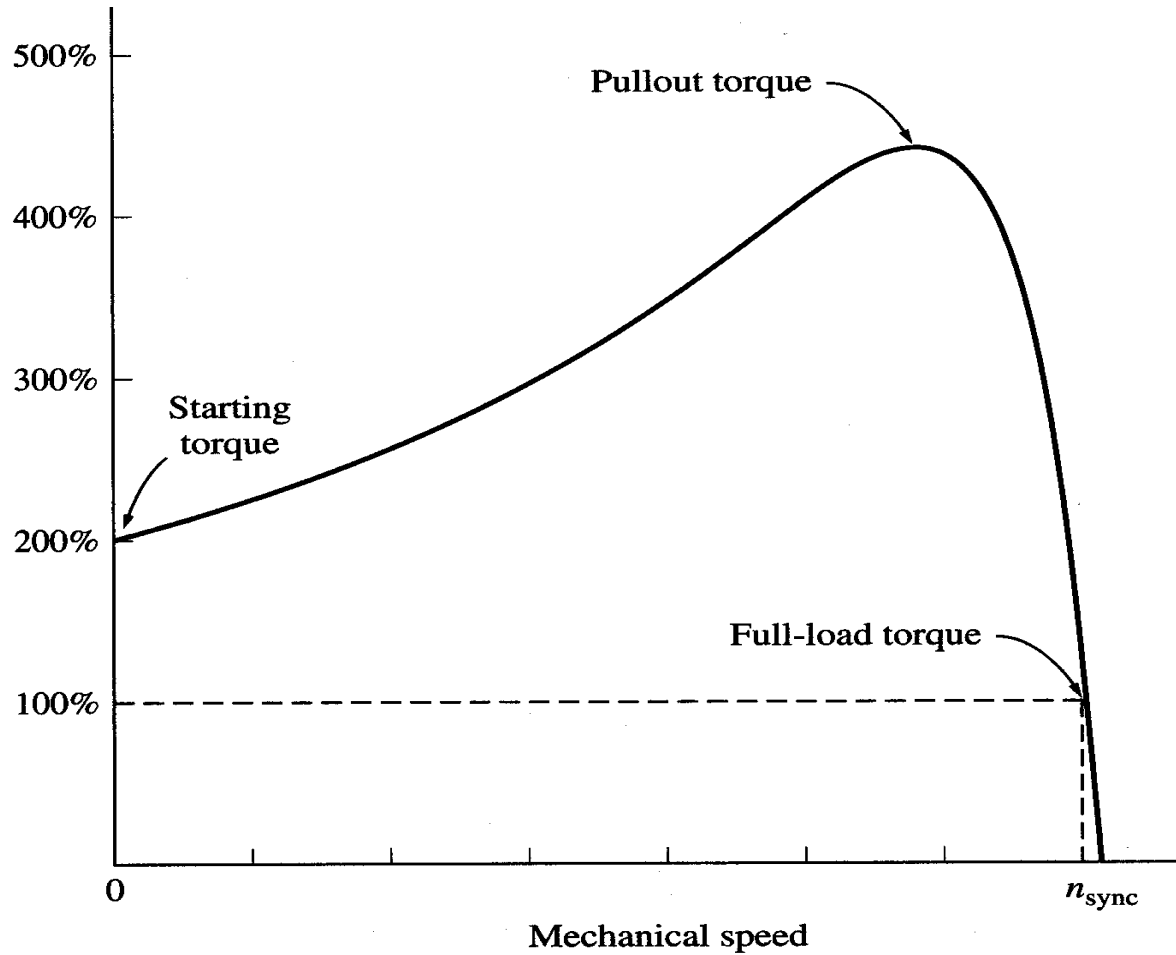

1. The induced torque is zero at synchronous speed. Discussed earlier.
2. The curve is nearly linear between no-load and full load. In this range, the rotor resistance is much greater than the reactance, so the rotor current, torque increase linearly with the slip.
3. There is a maximum possible torque that can't be exceeded. This torque is called *pullout torque* and is 2 to 3 times the rated full-load torque.
4. The starting torque of the motor is slightly higher than its full-load torque, so the motor will start carrying any load it can supply at full load.
5. The torque of the motor for a given slip varies as the square of the applied voltage.
6. If the rotor is driven faster than synchronous speed it will run as a generator, converting mechanical power to electric power.

Torque- Speed Characteristics

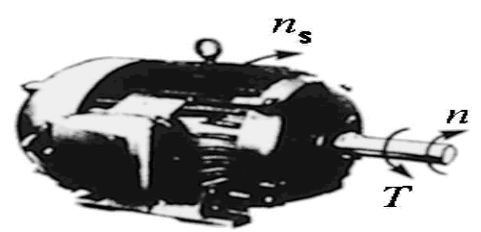
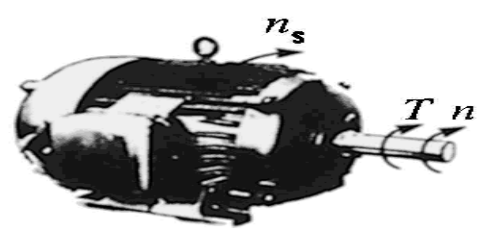
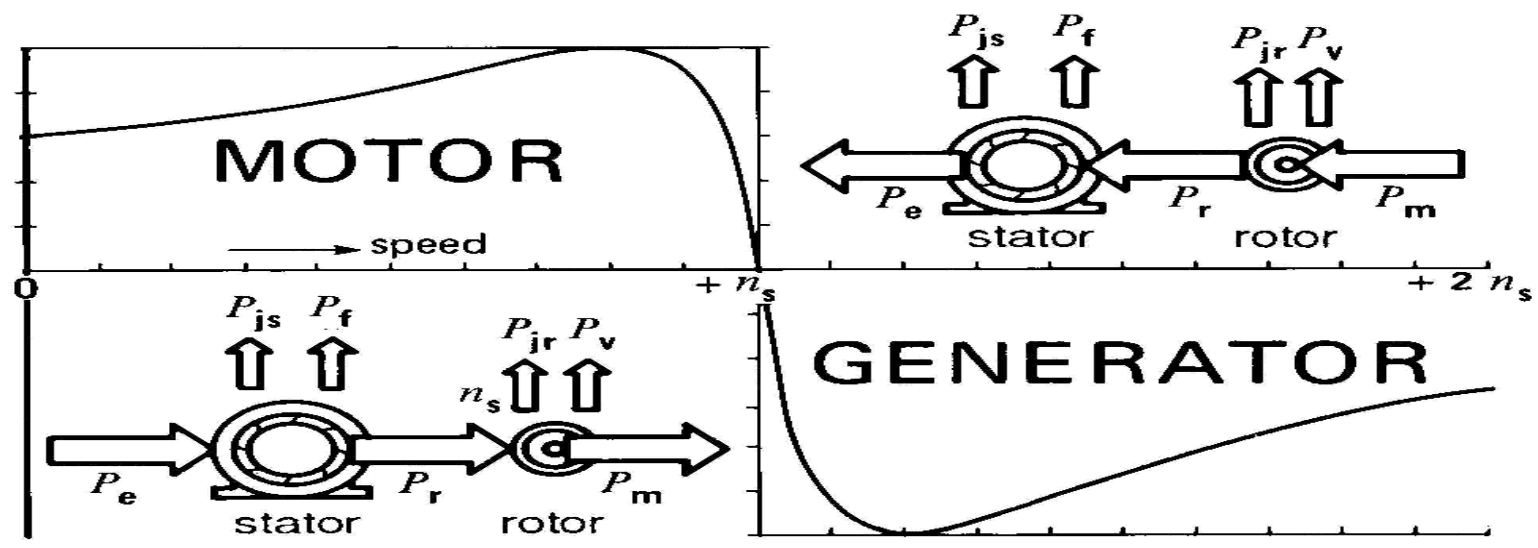

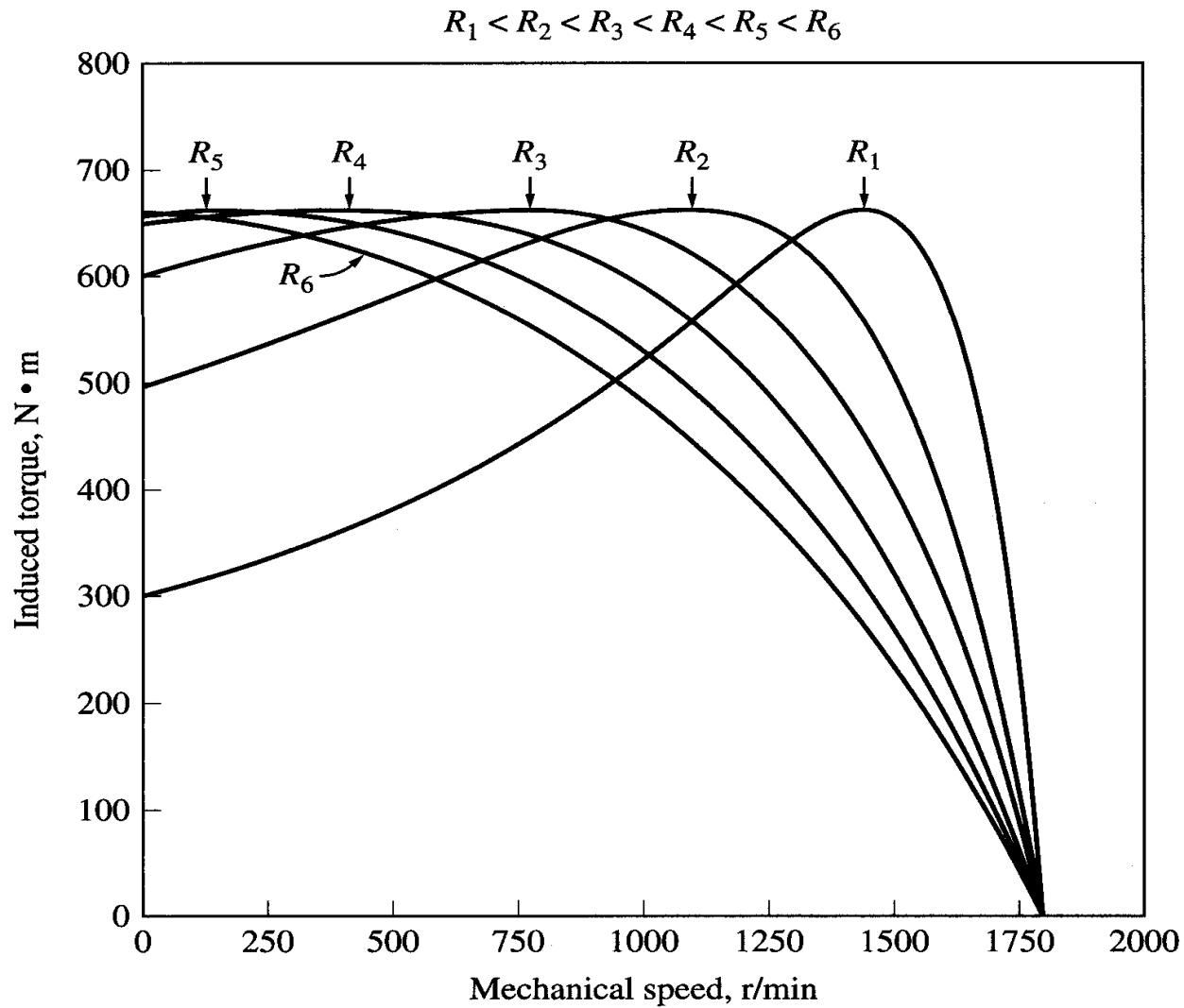

Numerical Problems on Torque

1. A 25 hp, 6 poles, 50 Hz, 3-phase induction motor has stator/ rotor ratio of 6/5. The stator and rotor impedances per phase are $(0.25 + j0.75)$ ohms and $(0.173 + j0.52)$ ohms respectively. Find the starting torque exerted by the motor when an external resistance of 1 ohm is inserted in each phase, the motor being started directly on the 400 V supply system. Assume star connection
2. A 40 kw, 3-phase slip-ring induction motor of negligible stator impedance runs at a speed of 0.96 time's synchronous speed at rated torque. The slip at maximum torque is 4 times the full load value. If the rotor resistance of the motor is increased by 5 times, determine: a) the speed, power output and rotor copper loss at rated torque b) The speed corresponding o maximum torque

3. The power input to a 6-pole, 50 Hz, 3-phase induction motor is 700 W at no load and 10 kw at full load. The no load copper loss may be assumed negligible while the full load stator and rotor copper losses are 295 W and 310 W respectively. Find the full load speed, shaft torque and efficiency of the motor assuming rotational and core losses to be equal.

No-load test

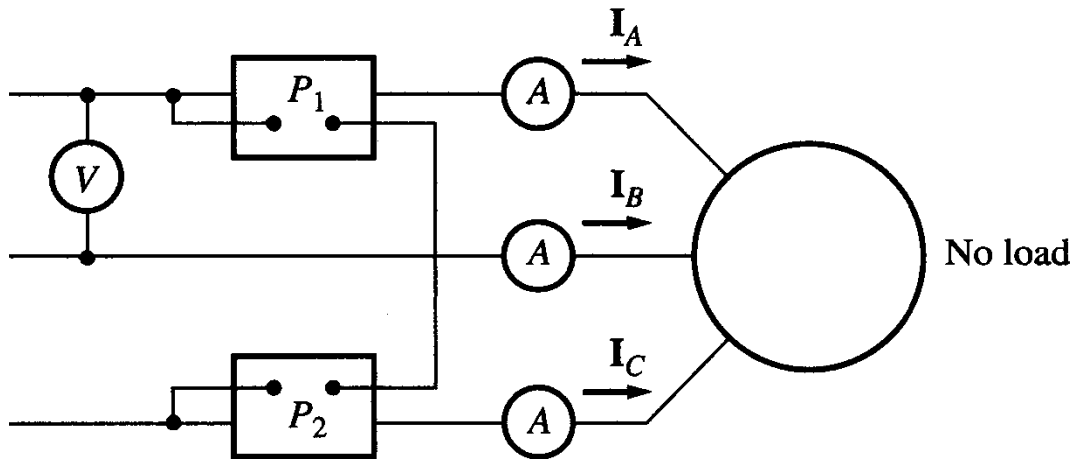

1. The motor is allowed to spin freely
2. The only load on the motor is the friction and windage losses, so all P_{conv} is consumed by mechanical losses
3. The slip is very small

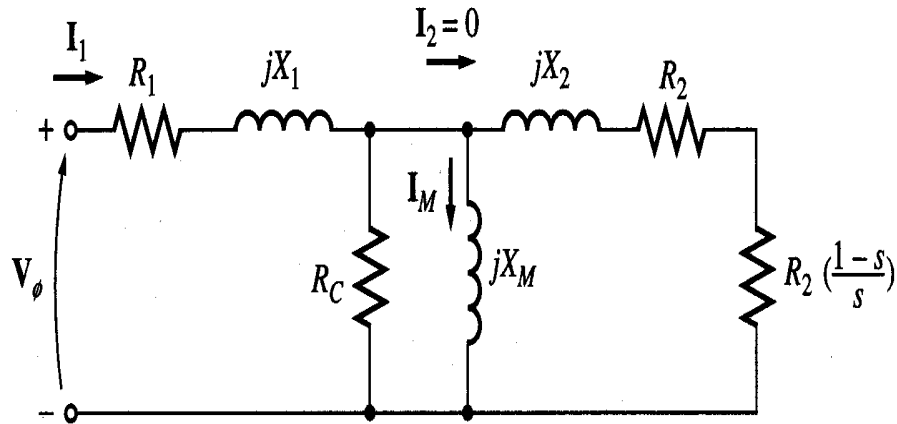

4. At this small slip

$$\frac{R_2(1-s)}{s} \approx R_2 \quad \& \quad \frac{R_2(1-s)}{s} \approx X_2$$

The equivalent circuit reduces to...

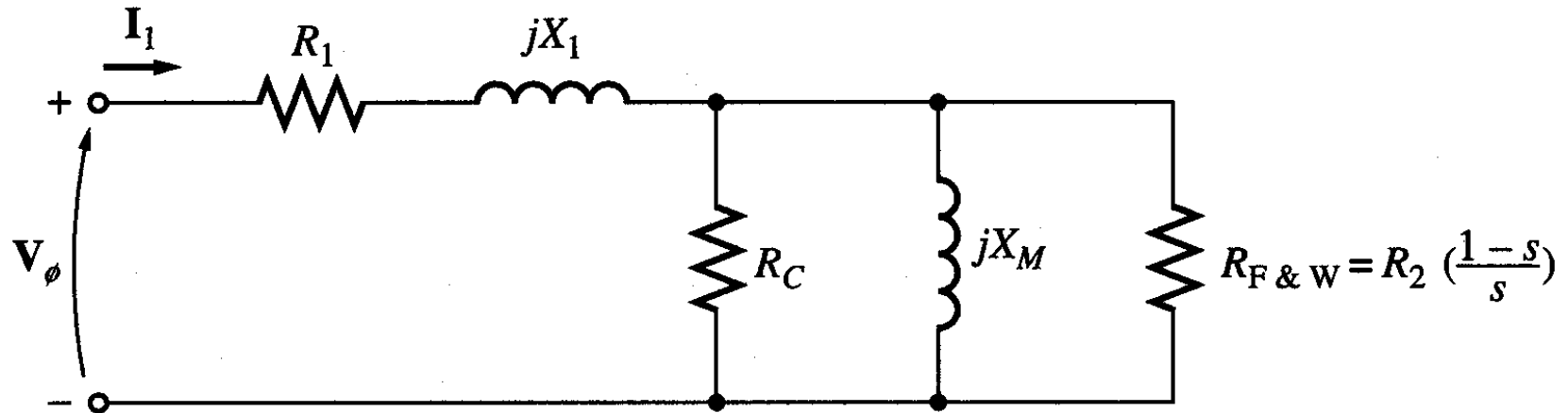

5. Combining R_C & R_{F+W} we get.....

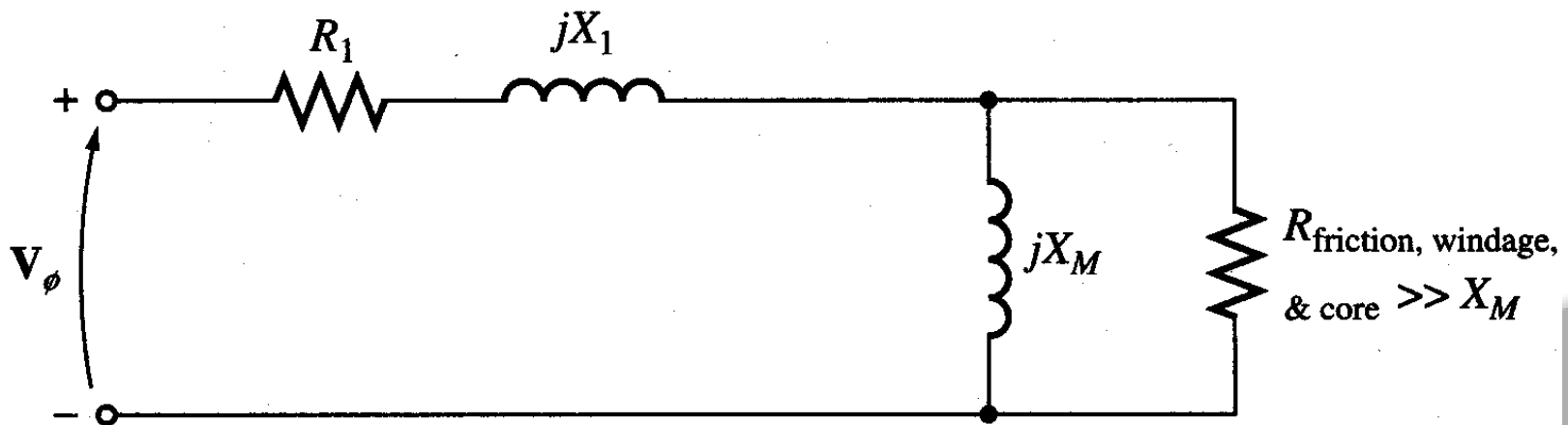

6. At the no-load conditions, the input power measured by meters must equal the losses in the motor.
7. The P_{RCL} is negligible because I_2 is extremely small because $R_2(1-s)/s$ is very large.
8. The input power equals

$$\begin{aligned} P_{in} &\equiv P_{SCL} + P_{core} + P_{F\&W} \\ &\equiv 3I_1^2 R_1 + P_{rot} \end{aligned}$$

$$P_{rot} = P_{core} + P_{F\&W}$$

9. The equivalent input impedance is thus approximately

$$\|Z_{eq}\| \equiv \frac{V_\phi}{I_{1,nl}} \approx X_1 + X_M$$

If X_1 can be found, in some other fashion, the magnetizing impedance X_M will be known

Blocked rotor test

- In this test, the rotor is locked or blocked so that it cannot move, a voltage is applied to the motor, and the resulting voltage, current and power are measured.

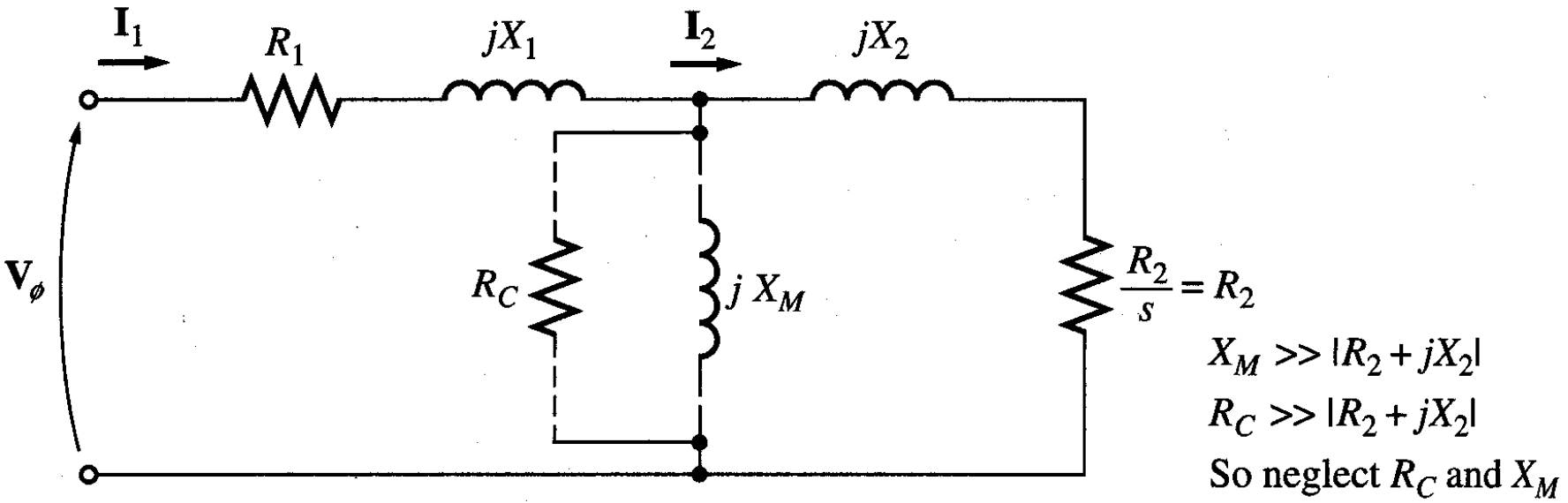

- The AC voltage applied to the stator is adjusted so that the current flow is approximately full-load value.
- The locked-rotor power factor can be found as

$$PF' \equiv \cos \theta \equiv \frac{P_{in}}{\sqrt{3}V_l I_l}$$

The magnitude of the total impedance

$$|Z_{LR}| \equiv \frac{V_\phi}{I}$$

$$\begin{aligned} |Z_{LR}| &= R_{LR} + jX'_{LR} \\ &= |Z_{LR}| \cos \theta + j|Z_{LR}| \sin \theta \end{aligned}$$

$$R_{LR} = R_1 + R_2$$

$$X'_{LR} = X'_1 + X'_2$$

Where X'_1 and X'_2 are the stator and rotor reactances at the test frequency respectively

$$R_2 = R_{LR} - R_1$$

$$X_{LR} = \frac{f_{rated}}{f_{test}} X'_{LR} = X_1 + X_2$$

Numerical Problems on Circle diagram

1. Draw the circle diagram of a 20 hp, 400 V, 50 Hz, 3- phase star- connected induction motor from the following test data (line values)

No load	400 V	9 A	Pf 0.2
Blocked rotor	200 V	50 A	Pf 0.4

From the circle diagram find (i) line current and power factor at full load (ii)

Maximum power output

2. Draw the circle diagram for a 5 hp, 200 V, 50 Hz, 4 pole, 3 – phase, star connected induction motor from the following data: (i) 200 V, 5A, 350 W (ii) 100 V, 26 A, 1700 W (iii) Rotor copper loss at standstill = half of the total copper loss. Estimate there from the full load current, power factor, speed and torque.
3. A 400 V, 3-Phase, 50 Hz, star connected induction motor has the following

test results:

No load test	400 V	8.5 A	1100 W
Blocked rotor test	180 V	45 A	5799 W

Calculate the line current and power factor when operating at 4% slip. The stator resistance per phase is 0.5Ω

Numerical problems on circle diagram

1. Draw the circle diagram of a 100 hp, 400 V, 50 Hz, 3- phase star-connected induction motor from the following test data (line values)

No load test	400 V	9 A	Pf 0.3
Blocked rotor test	200 V	100 A	Pf 0.45

From the circle diagram find (i) line current and power factor at full load
(ii) Maximum power output

2. Draw the circle diagram for a 20 hp, 200 V, 50 Hz, 4 pole, 3 – phase, star connected induction motor from the following data: (i) 200 V, 9A, 425 W
(ii) 100 V, 59 A, 2100 W (iii) Rotor copper loss at standstill = Quarter of the total copper loss. Estimate there from the full load current, power factor, speed and torque

3. A 400 V, 3-Phase, 50 Hz, star connected induction motor has the following test results:

No load test	400 V	9.5 A	1150 W
Blocked rotor test	195 V	63A	6899 W

Calculate the line current and power factor when operating at 5% slip.

The stator resistance per phase is 0.5Ω

Starting methods

Full Voltage Starting Method for Squirrel Cage Induction Motor:

Direct on Line Starting Method

- This method is also known as the DOL method for starting the three phase squirrel cage induction motor. In this method we directly switch the stator of the three phase squirrel cage induction motor on to the supply mains. The motor at the time of starting draws very high starting current (about 5 to 7 times the full load current) for the very short duration. The amount of current drawn by the motor depends upon its design and size. But such a high value of current does not harm the motor because of rugged construction of the squirrel cage induction motor.

Reduced voltage method for starting squirrel cage induction motor:

In reduced voltage method we have three different type of starting method and these are written below:

- Stator resistor starting method
- Auto transformer starting method
- Star delta starting method
- Now let us discuss each of these methods in detail.
- Stator Resistor Starting Method

Stator resistor starting method

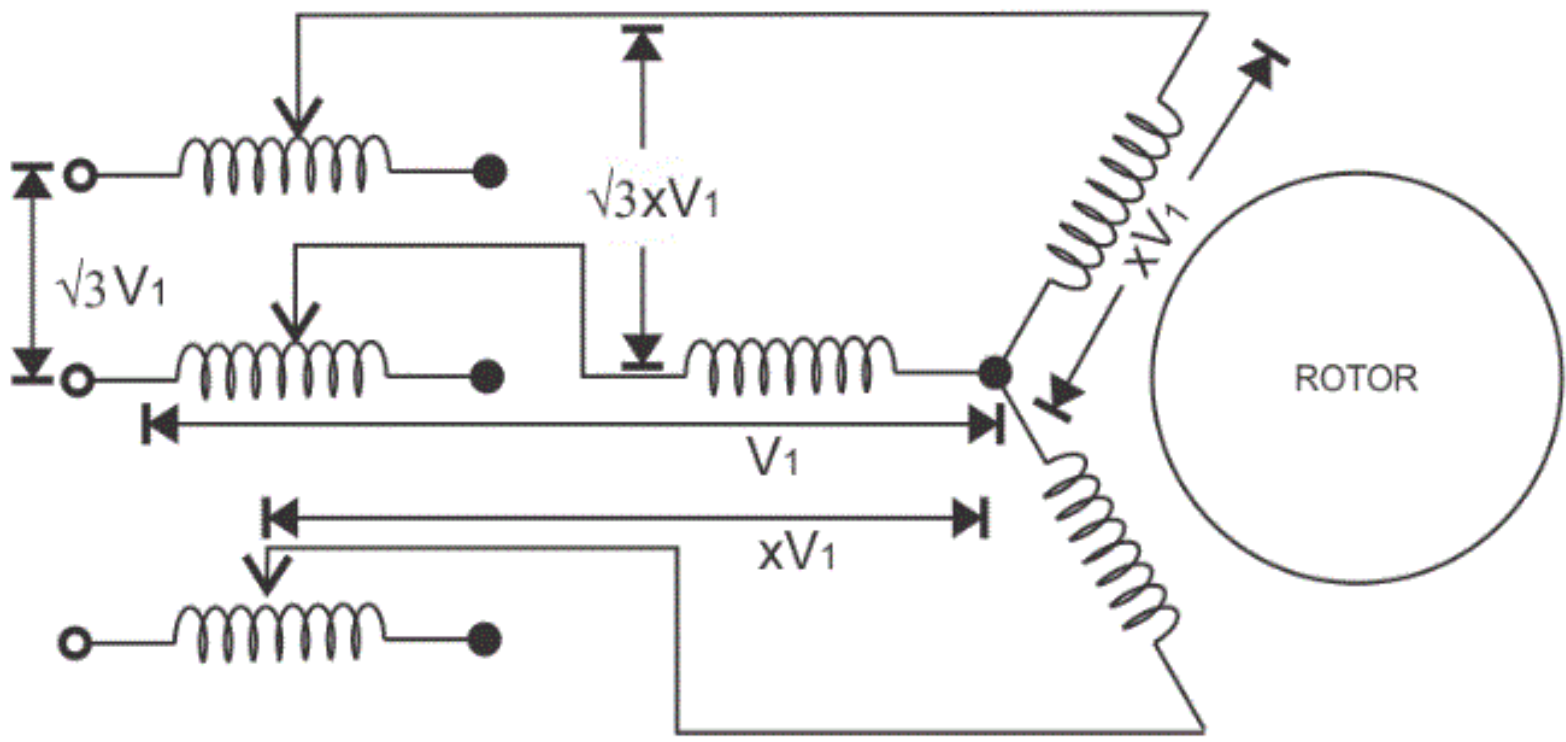

Auto Transformer Starting Method

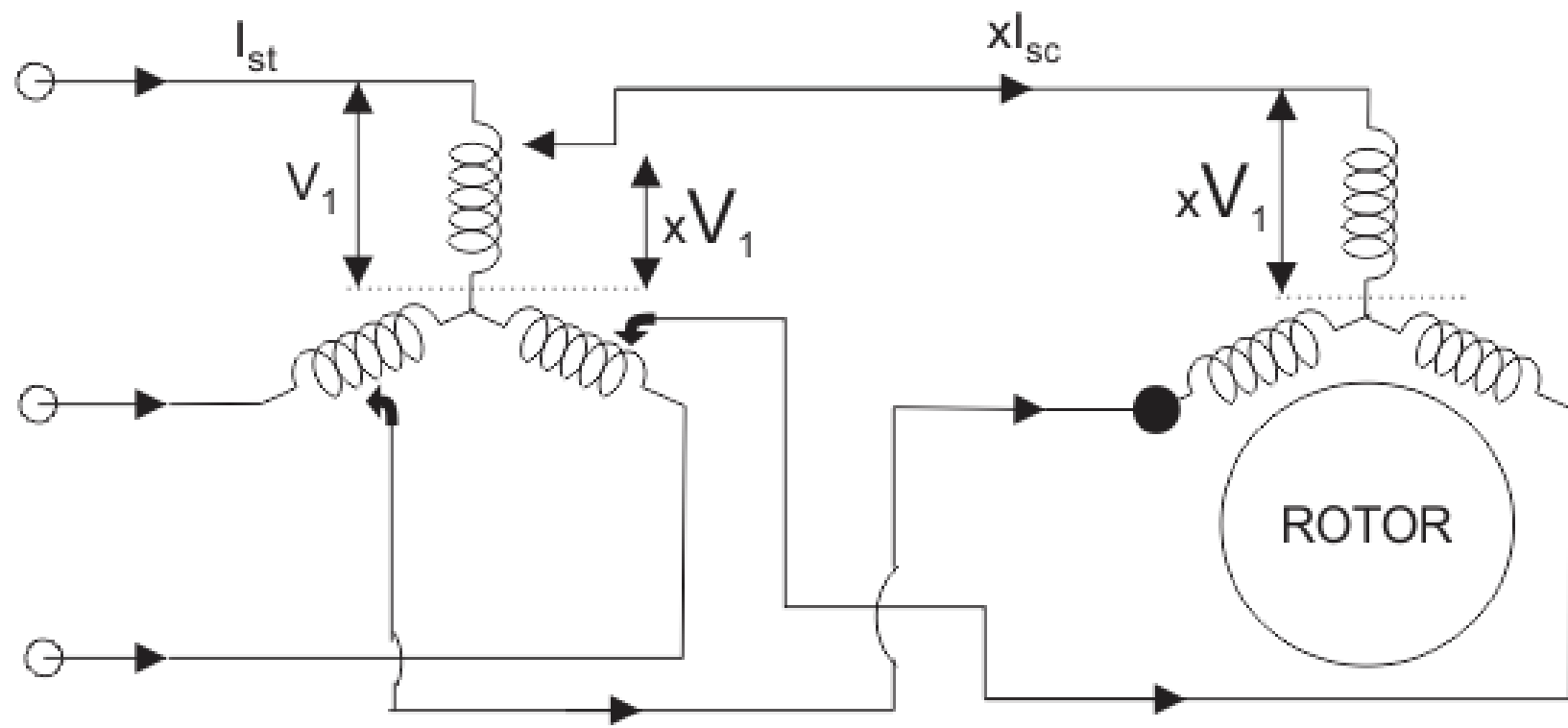

Pertaining to Auto-Transfer Starting

Star-Delta Starting Method

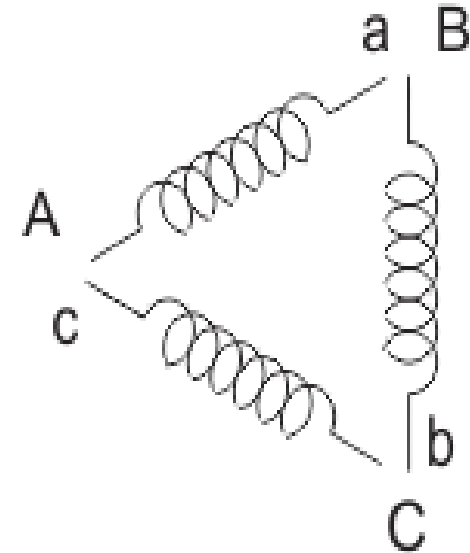
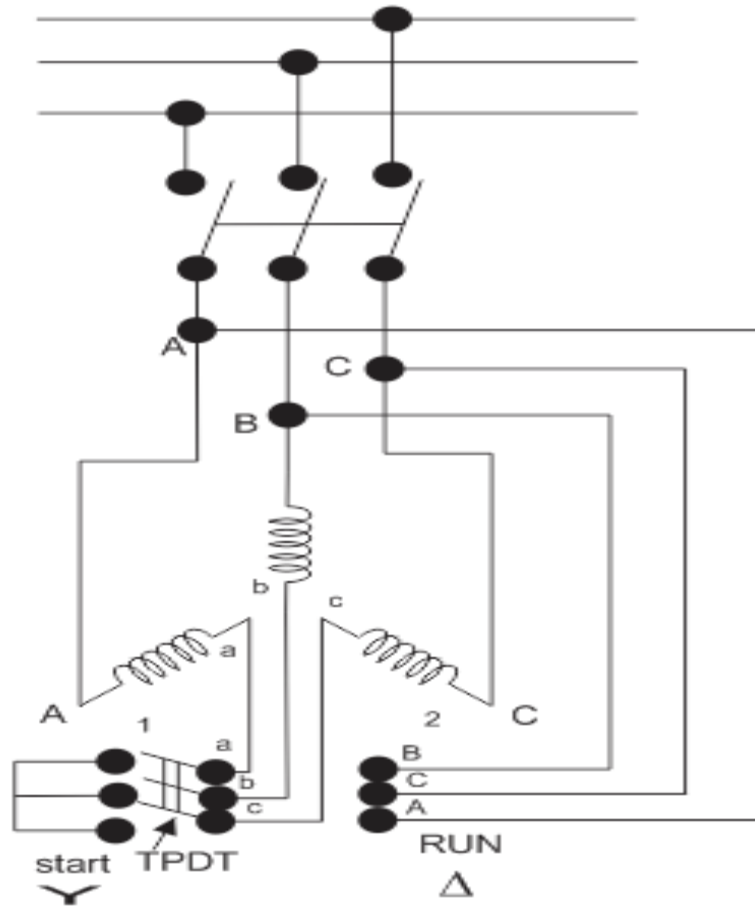

Star Delta

Addition of External Resistances in Rotor Circuit

- This will decrease the starting current, increases the starting torque and also improves the power factor. The circuit diagram is shown below: In the circuit diagram, the three slip rings shown are connected to the rotor terminals of the wound rotor motor. At the time of starting of the motor, the entire external resistance is added in the rotor circuit. Then the external rotor resistance is decreased in steps as the rotor speeds up, however the motor torque remain maximum during the acceleration period of the motor.
- Induction motor always operates at lagging power factor while the synchronous motor can operate at both lagging and leading power factor.

- In an induction motor the value of maximum torque is directly proportional to the square of the supply voltage while in case of synchronous machine the maximum torque is directly proportional to the supply voltage.
- In an induction motor we can easily control speed while with synchronous motor, in normal condition we cannot control speed of the motor. (d) Induction motor has inherent self starting torque while the synchronous motor has no inherent self starting torque
- We cannot use induction motor to improve the power factor of the supply system while with the use of synchronous motor we can improve the power factor of the supply system.

- It is a singly excited machine means there is no requirement of dc excitation while the synchronous motor is doubly excited motor means there is requirement of separate dc excitation.
- In case of induction motor on increasing the load the speed of the motor decreases while with the speed of the synchronous motor remains constant.

Induction Generator

- Induction machine is sometimes used as a generator. It is also called Asynchronous Generator. What are the conditions when the poly phase (here three phase) induction machine will behave as an induction generator? The following are conditions when the induction machine will behave as an *induction* generator are written below:
- Slip becomes negative due to this the rotor current and rotor emf attains negative value.
- The prime mover torque becomes opposite to electric torque. Now let us discuss how we can achieve these conditions. Suppose that an induction machine is coupled with the prime mover whose speed can be controlled. If the speed of the prime mover is increased such that the slip becomes negative (i.e. speed of the prime mover becomes greater than the synchronous speed).

Isolated Induction Generator

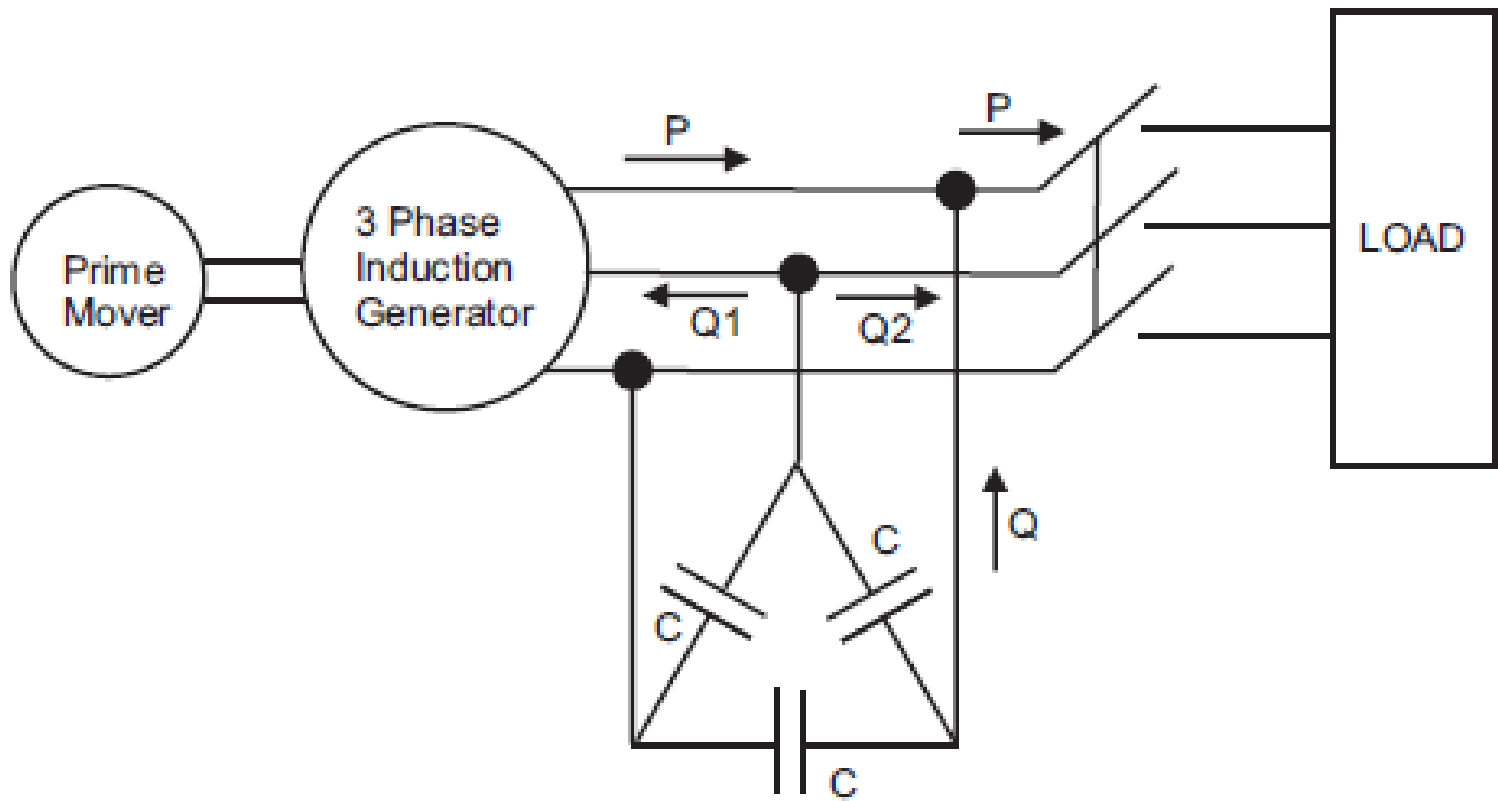

- This type of generator is also known as self excited generator. Now why it is called self excited? It is because it uses capacitor bank which is connected across its stator terminals
- The function of the capacitor bank is to provide the lagging reactive power to the induction generator as well as load.
- The cumulative process of voltage generation continues till the saturation curve of the induction generator cuts the capacitor load line at some point. This point is marked as f in the given curve.

iii) Number of stator slots and conductors per slot

Considering the guide lines for selection of number of slots

Selecting the number of slots/pole/phase = 3

Total number of slots = $3 \times 12 \times 3 = 108$

Slot pitch = $\pi D/S$

= $\pi \times 132 / 108$

= 2.84 cm (quite satisfactory)

Number of conductors per slot = $2472/108 \approx 24$

Hence total number of conductors = $24 \times 108 = 2592$

Turns per phase = $2592/6 = 432$

- Slot loading:
- Full load current = $500 \times 10^3 / (\sqrt{3} \times 6600) = 43.7$ amps
- Slot loading = current per conductor x number of conductors/ slot
- = 43.7×24
- = 1048.8 (satisfactory)

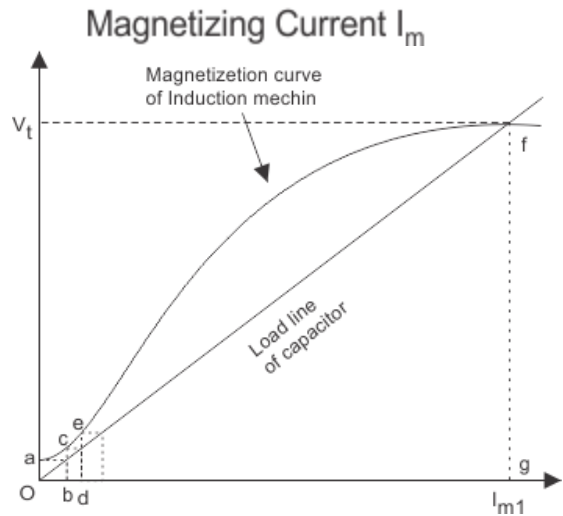
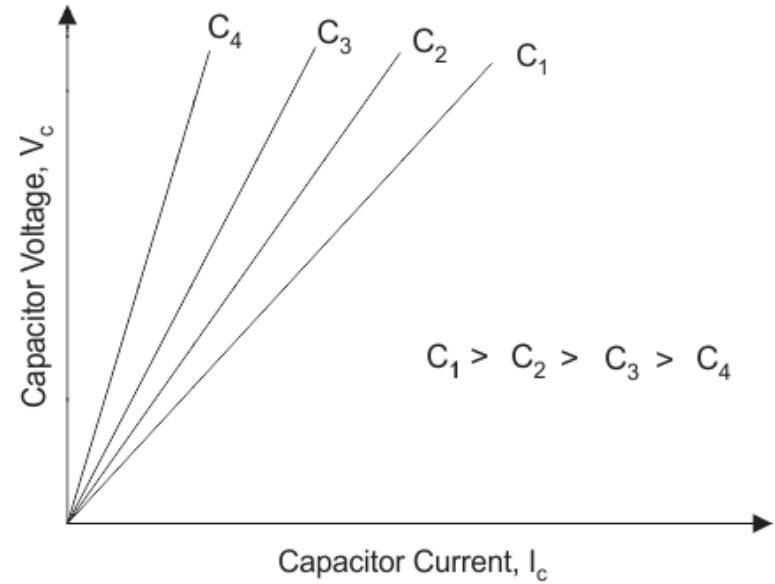
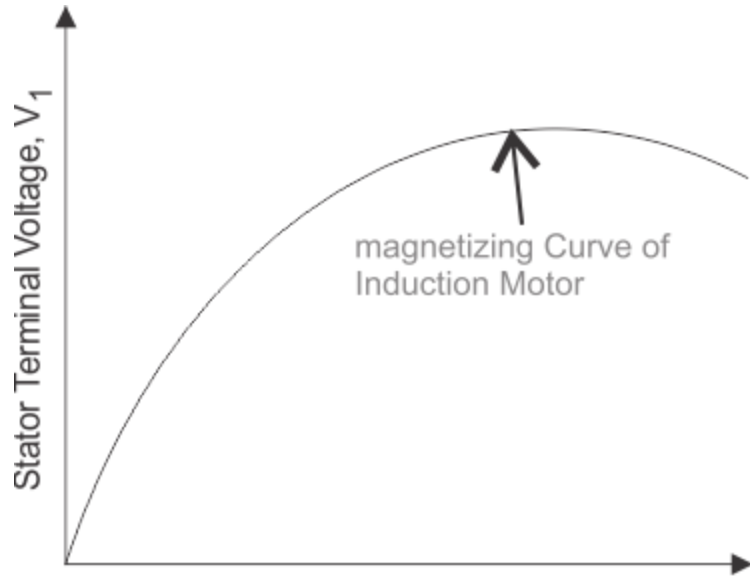

➤ Speed control by changing applied voltage

- From the torque equation of the induction machine given in eqn.17, we can see that the torque depends on the square of the applied voltage. The variation of speed torque curves with respect to the applied voltage is shown in fig. 18. These curves show that the slip at maximum torque s^{\wedge} remains same, while the value of stall torque comes down with decrease in applied voltage. The speed range for stable operation remains the same.

➤ Rotor resistance control

- For all its advantages, the scheme has two serious drawbacks. Firstly, in order to vary the rotor resistance, it is necessary to connect external variable resistors (winding resistance itself cannot be changed). This therefore necessitates a slip-ring machine, since only in that case rotor terminals are available outside. For cage rotor machines, there are no rotor terminals. Secondly, the method is not very efficient since the additional resistance and operation at high slips entails dissipation.

➤ **Cascade control**

- The power drawn from the rotor terminals could be spent more usefully. Apart from using the heat generated in meaningful ways, the slip ring output could be connected to another induction machine. The stator of the second machine would carry slip frequency currents of the first machine which would generate some useful mechanical power. A still better option would be to mechanically couple the shafts of the two machines together. This sort of a connection is called cascade connection

➤ Pole changing schemes

- Sometimes induction machines have a special stator winding capable of being externally connected to form two different number of pole numbers. Since the synchronous speed of the induction machine is given by $n_s = f_s/p$ (in rev./s) where p is the number of pole pairs, this would correspond to changing the synchronous speed. With the slip now corresponding to the new synchronous speed, the operating speed is changed



MODULE – III

ALTERNATORS

Types of synchronous machines

- According to the arrangement of armature and field winding, the synchronous machines are classified as rotating armature type or rotating field type.
- In rotating armature type the armature winding is on the rotor and the field winding is on the stator. The generated emf or current is brought to the load via the slip rings. These type of generators are built only in small units.
- In case of rotating field type generators field windings are on the rotor and the armature windings are on the stator. Here the field current is supplied through a pair of slip rings and the induced emf or current is supplied to the load via the stationary terminals.

- Based on the type of the prime movers employed the synchronous generators are classified as
- Hydro generators : The generators which are driven by hydraulic turbines are called hydro generators. These are run at lower speeds less than 1000 rpm.
- Turbo generators: These are the generators driven by steam turbines. These generators are run at very high speed of 1500rpm or above.
- Engine driven Generators: These are driven by IC engines. These are run at a speed less than 1500 rpm.

- **Salient pole Machines:**

These type of machines have salient pole or projecting poles with concentrated field windings. This type of construction is for the machines which are driven by hydraulic turbines or Diesel engines

- **Non salient pole or cylindrical rotor or Round rotor Machines:**

These machines are having cylindrical smooth rotor construction with distributed field winding in slots. This type of rotor construction is employed for the machine driven by steam turbines

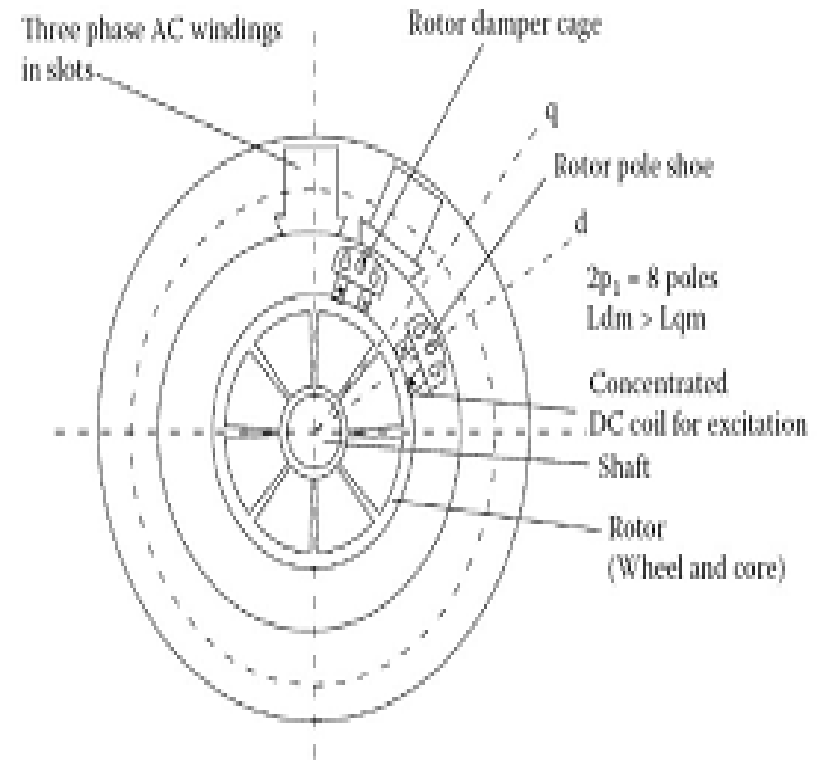
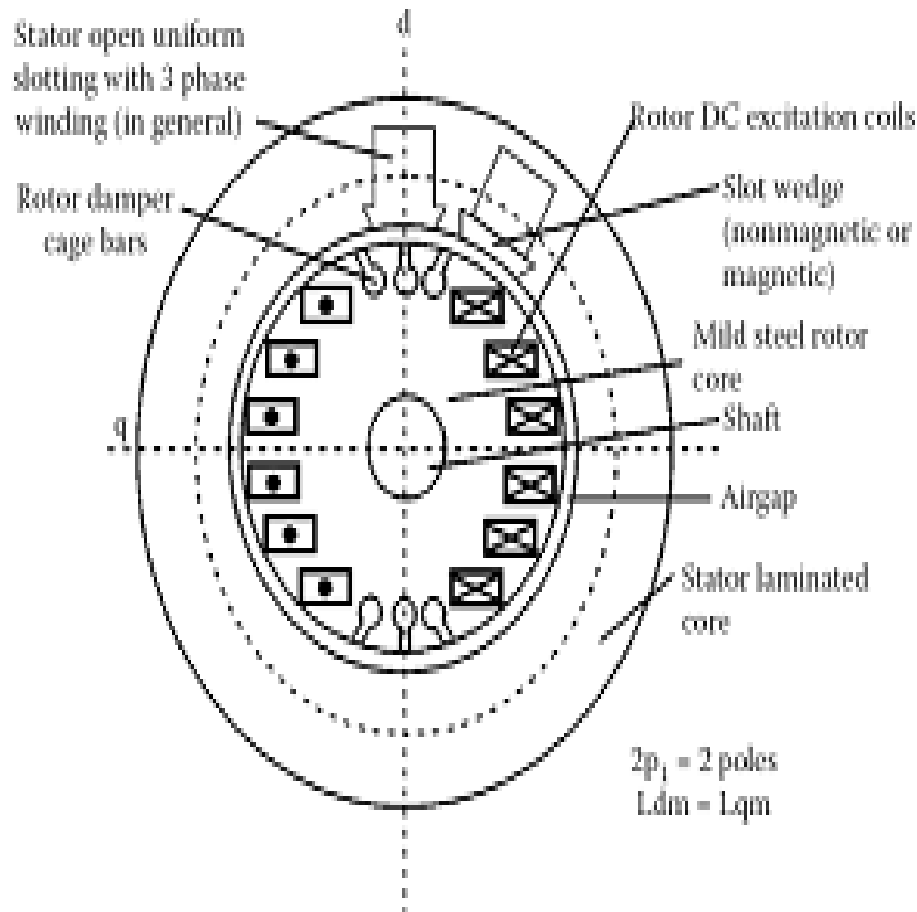

Operation of Alternators

- Similar to the case of DC generator, the behavior of a Synchronous generator connected to an external load is different than that at no-load. In order to understand the performance of the Synchronous generator when it is loaded, consider the flux distributions in the machine when the armature also carries a current. Unlike in the DC machine in alternators the emf peak and the current peak will not occur in the same coil due to the effect of the power factor of the load
- The current and the induced emf will be at their peaks in the same coil only for UPF loads. For zero power factor lagging loads, the current reaches its peak in a coil which falls behind that coil wherein the induced emf is at its peak by 90 electrical degrees or half a pole-pitch.

- Likewise for zero power factor leading loads, the current reaches its peak in a coil which is ahead of that coil wherein the induced emf is at its peak by 90 electrical degrees or half a pole-pitch. For simplicity, assume the resistance and leakage reactance of the stator windings to be negligible.
- Also assume the magnetic circuit to be linear i.e. the flux in the magnetic circuit is deemed to be proportional to the resultant ampere-turns - in other words the machine is operating in the linear portion of the magnetization characteristics. Thus the emf induced is the same as the terminal voltage, and the phase-angle between current and emf is determined only by the power factor (P.f) of the external load connected to the synchronous generator.

Windings in Alternators:

In case of three phase alternators the following types of windings are employed.

- Lap winding,
- wave winding and
- Mush winding.

Based on pitch of the coil

- full pitched
- short pitched windings

Based on number of layers

- Single layer
- Double layer

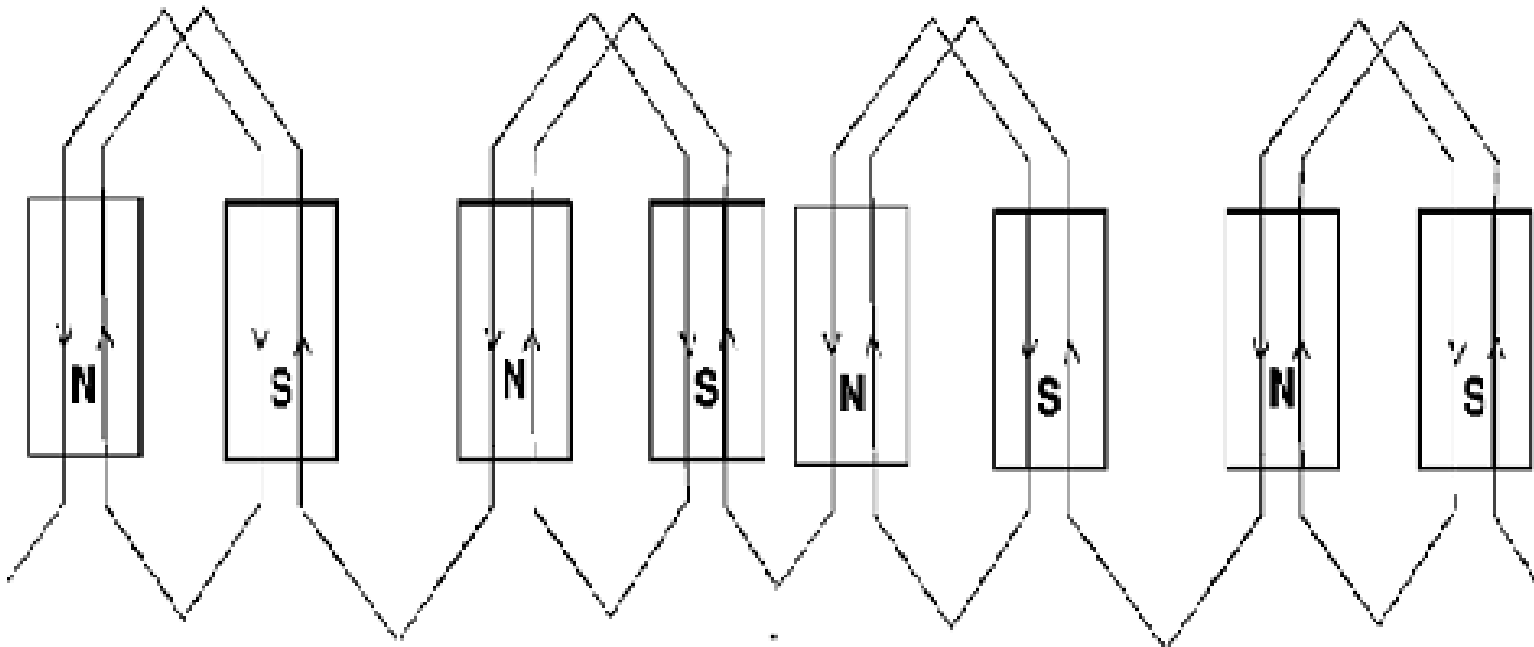

Figure: 23. Single layer winding

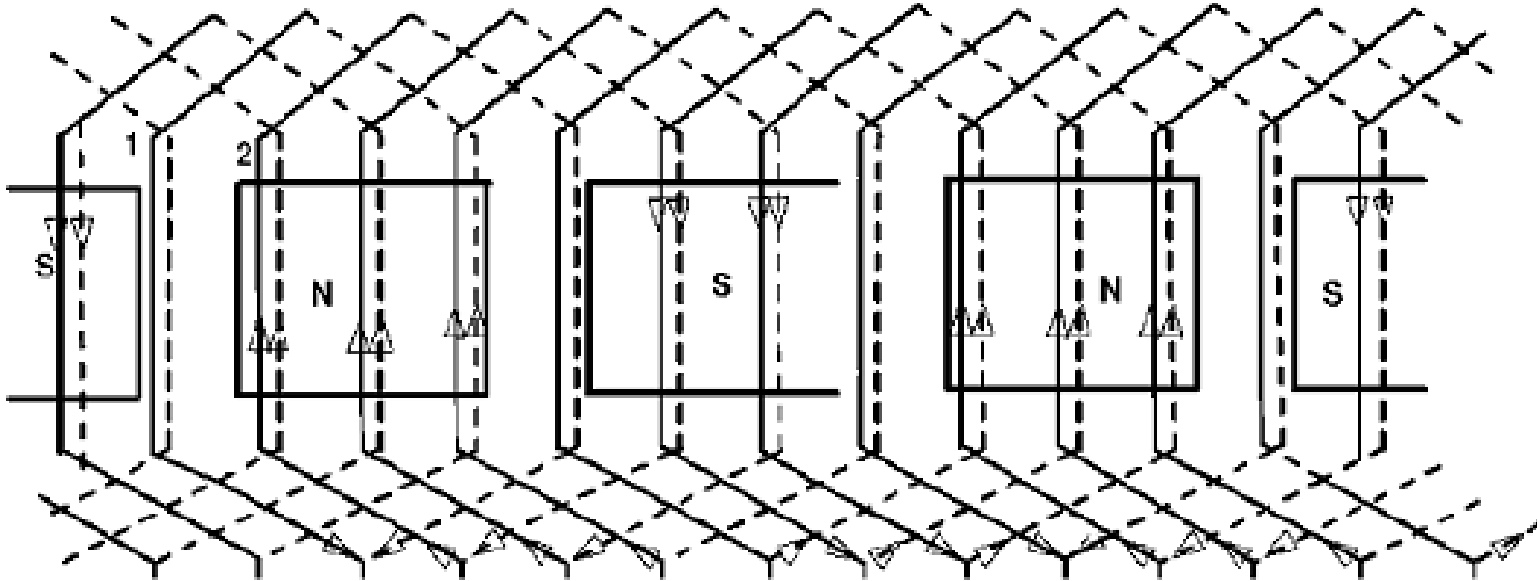

Figure: 24. Double layer winding

EMF Equation

Consider the following

- Φ = flux per pole in wb
 - P = Number of poles
 - N_s = Synchronous speed in rpm
 - f = frequency of induced EMF in Hz
 - Z = total number of stator conductors
 - Z_{ph} = conductors per phase connected in series
 - T_{ph} = Number of turns per phase
 - Assuming concentrated winding, considering one conductor placed in a slot
- According to Faradays Law electromagnetic induction,
- The average value of EMF induced per conductor in one revolution
 - $e_{avg} = d/dt e_{avg}$ = Change of Flux in one revolution/ Time taken for one revolution
 - Change of Flux in one revolution = P
 - Time taken for one revolution = $60/N_s$ seconds

- Hence $e_{avg} = (p) / (60/N_s) = PN_s / 60$
- We know $f = PN_s / 120$
- Hence $PN_s / 60 = 2f$
- Hence $e_{avg} = 2f$ volts
- Hence average EMF per turn = $2 \times 2f$ volts = $4f$ volts
- If there are T_{ph} , number of turns per phase connected in series, then average EMF induced in T_{ph} turns is
- $E_{ph, avg} = T_{ph} \times e_{avg} = 4 f \Phi T_{ph}$ volts
- Hence RMS value of EMF induced $E = 1.11 \times E_{ph, avg}$
$$= 1.11 \times 4 f \Phi T_{ph} \text{ volts}$$
$$= 4.44 f \Phi T_{ph} \text{ volts}$$
- This is the general EMF equation for the machine having concentrated and full pitched winding.
- In practice, alternators will have short pitched winding and hence coil span will not be 180° , but one or two slots short than the full pitch.

Distribution and Pitch Factor

Pitch Factor:

- Pitch factor $K_p = \text{EMF induced in a short pitched coil} / \text{EMF induced in a full pitched coil} = (2E \cos \alpha/2) / 2E$
- $K_p = \cos \alpha/2$
- Where α is called chording angle.

Distribution Factor: Even though we assumed concentrated winding in deriving EMF equation, in practice an attempt is made to distribute the winding in all the slots coming under a pole. Such a winding is called distributed winding.

- In concentrated winding the EMF induced in all the coil sides will be same in magnitude and in phase with each other. In case of distributed winding the magnitude of EMF will be same but the EMF s induced in each coil side will not be in phase with each other as they are distributed in the slots under a pole.
- Hence the total EMF will not be same as that in concentrated winding but will be equal to the vector sum of the EMF s induced. Hence it will be less than that in the concentrated winding

- Distribution factor $K_d = \text{EMF induced in a distributed winding} / \text{EMF induced in a concentrated winding} = \text{vector sum of the EMF} / \text{arithmetic sum of the EMF}$
- The EMF induced in concentrated winding with m slots per pole per phase = mE volts.
- Fig below shows the method of calculating the vector sum of the voltages in a distributed winding having a mutual phase difference of β . When m is large curve ACEN will form the arc of a circle of radius r .
- From the figure below $AC = 2r \sin \beta/2$

- Hence arithmetic sum = $m2r \sin\beta/2$
- Now the vector sum of the EMF $s = 2r \sin m\beta/2$
- Hence the distribution factor $K_d = \text{vector sum of the EMF} / \text{arithmetic sum of the EMF} = (2r \sin m\beta/2) / (m \times 2r \sin \beta/2)$
- $K_d = (\sin m\beta/2) / (m \sin \beta/2)$

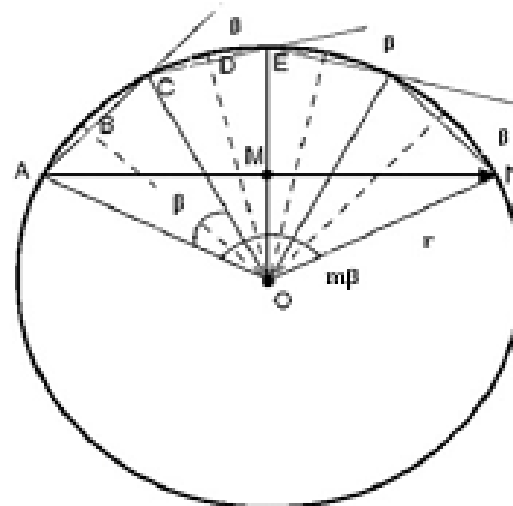

In practical machines the windings will be generally short pitched and distributed over the periphery of the machine. Hence in deducing the EMF equation both pitch factor and distribution factor has to be considered.

Hence the general EMF equation including pitch factor and distribution factor can be given as EMF induced per phase =

$$4.44 f T_{ph} \times K_p K_d \text{ volts}$$

$$E_{ph} = 4.44 K_p K_d f T_{ph} \text{ volts}$$

Hence the line Voltage $E_L = \sqrt{3} \times \text{phase voltage} = \sqrt{3} E_{ph}$

- When the uniformly sinusoidal distributed air gap flux is cut by either the stationary or rotating armature sinusoidal EMF is induced in the alternator. Hence the nature of the waveform of induced EMF and current is sinusoidal. But when the alternator is loaded waveform will not continue to be sinusoidal or becomes non sinusoidal. Such non sinusoidal wave form is called complex wave form. By using Fourier series representation it is possible to represent complex non sinusoidal waveform in terms of series of sinusoidal components called harmonics, whose frequencies are integral multiples of fundamental wave. The fundamental wave form is one which is having the frequency same as that of complex wave.
- The waveform which is of the frequency twice that of the fundamental is called second order harmonic.

- These harmonic components can be represented as follows.

$$\text{Fundamental: } e_1 = E_{m1} \sin (\omega t \pm \theta_1)$$

$$\text{2nd Harmonic } e_2 = E_{m2} \sin (2\omega t \pm \theta_2)$$

$$\text{3rd Harmonic } e_3 = E_{m3} \sin (3\omega t \pm \theta_3)$$

$$\text{5th Harmonic } e_5 = E_{m5} \sin (5\omega t \pm \theta_5) \text{ etc.}$$

- In case of alternators as the field system and the stator coils are symmetrical the induced EMF will also be symmetrical and hence the generated EMF in an alternator will not contain any even harmonics.

Slot Harmonics

- As the armature or stator of an alternator is slotted, some harmonics are induced into the EMF which is called slot harmonics. The presence of slot in the stator makes the air gap reluctance at the surface of the stator non uniform. Since in case of alternators the poles are moving or there is a relative motion between the stator and rotor, the slots and the teeth alternately occupy any point in the air gap. Due to this the reluctance or the air gap will be continuously varying.
- Due to this variation of reluctance ripples will be formed in the air gap between the rotor and stator slots and teeth. This ripple formed in the air gap will induce ripple EMF called slot harmonics.

Minimization of Harmonics:

To minimize the harmonics in the induced waveforms following methods are employed:

- Distribution of stator winding.
- Short Chording
- Fractional slot winding
- Skewing
- Larger air gap length.

Effect of Harmonics on induced EMF:

- The harmonics will affect both pitch factor and distribution factor and hence the induced EMF. In a well designed alternator the air gap flux density distribution will be symmetrical and hence can be represented in Fourier series as follows.
- $B = B_{m1} \sin \omega t + B_{m3} \sin 3\omega t + B_{m5} \sin 5\omega t + \dots$
- The EMF induced by the above flux density distribution is given by $e = E_{m1} \sin \omega t + E_{m3} \sin 3\omega t + E_{m5} \sin 5\omega t + \dots$

- The RMS value of the resultant voltage induced can be given as

$$E_{ph} = \sqrt{[(E_1)^2 + (E_3)^2 + (E_5)^2 + \dots \dots \dots (E_n)^2]}$$

And line voltage $E_{Line} = \sqrt{3} \times E_{ph}$

Effect of Harmonics of pitch and distribution Factor:

- The pitch factor is given by $K_p = \cos \alpha/2$, where α is the chording angle.
- For any harmonic say n^{th} harmonic the pitch factor is given by $K_{pn} = \cos \alpha/2$
- The distribution factor is given by $K_d = (\sin m\beta/2) / (m \sin \beta/2)$
- For any harmonic say n^{th} harmonic the distribution factor is given by

$$K_{dn} = (\sin m n\beta/2) / (m \sin n\beta/2)$$

Armature Reaction

- The useful flux which links with both windings is due to combined MMF of the armature winding and field winding. When the armature winding of an alternator carries current then an MMF sets in armature. This armature MMF reacts with field MMF producing the resultant flux, which differs from flux of field winding alone.
- The effect of armature reaction depends on nature of load (power factor of load). At no load condition, the armature has no reaction due to absence of armature flux. When armature delivers current at unity power factor load, then the resultant flux is displaced along the air gap towards the trailing pole tip.

- Under this condition, armature reaction has distorting effect on MMF wave as shown in Figure. At zero lagging power factor loads the armature current is lagging by 90° with armature voltage.
- Under this condition, the position of armature conductor when inducing maximum EMF is the centre line of field MMF. Since there is no distortion but the two MMF are in opposition, the armature reaction is now purely demagnetizing as shown in Figure. Now at zero power factors leading, the armature current leads armature voltage by 90° .
- Under this condition, the MMF of armature as well as the field winding is in same phase and additive

(a) Unity Power Factor

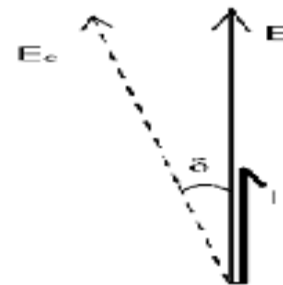
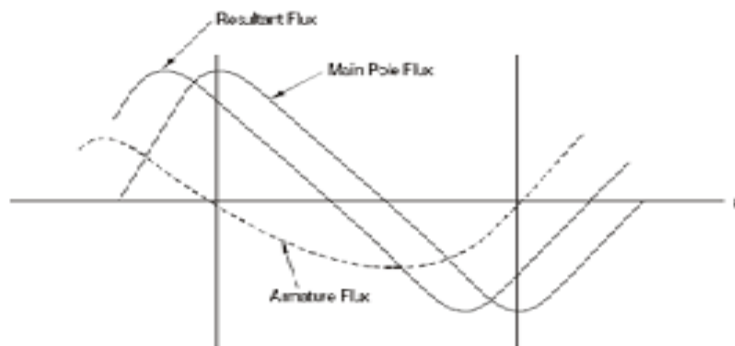
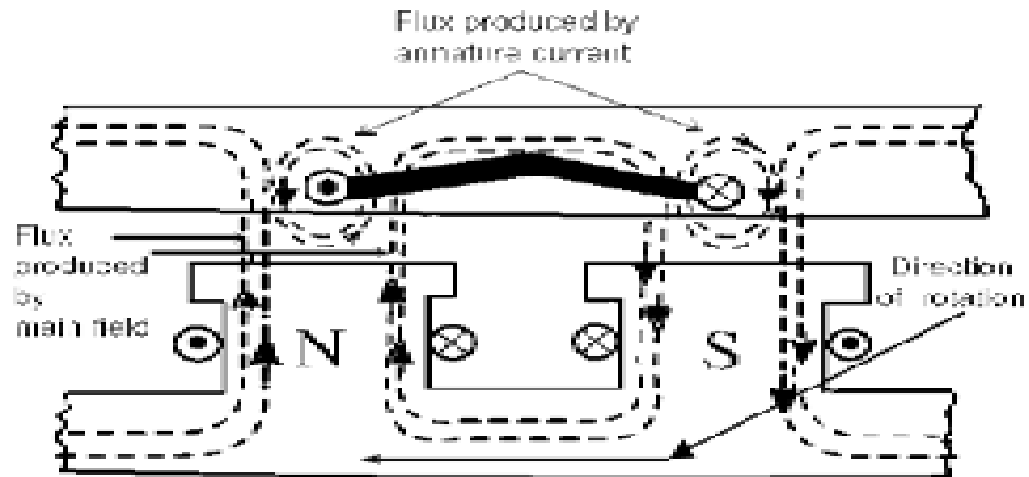

(b) Zero Power Factor Lagging

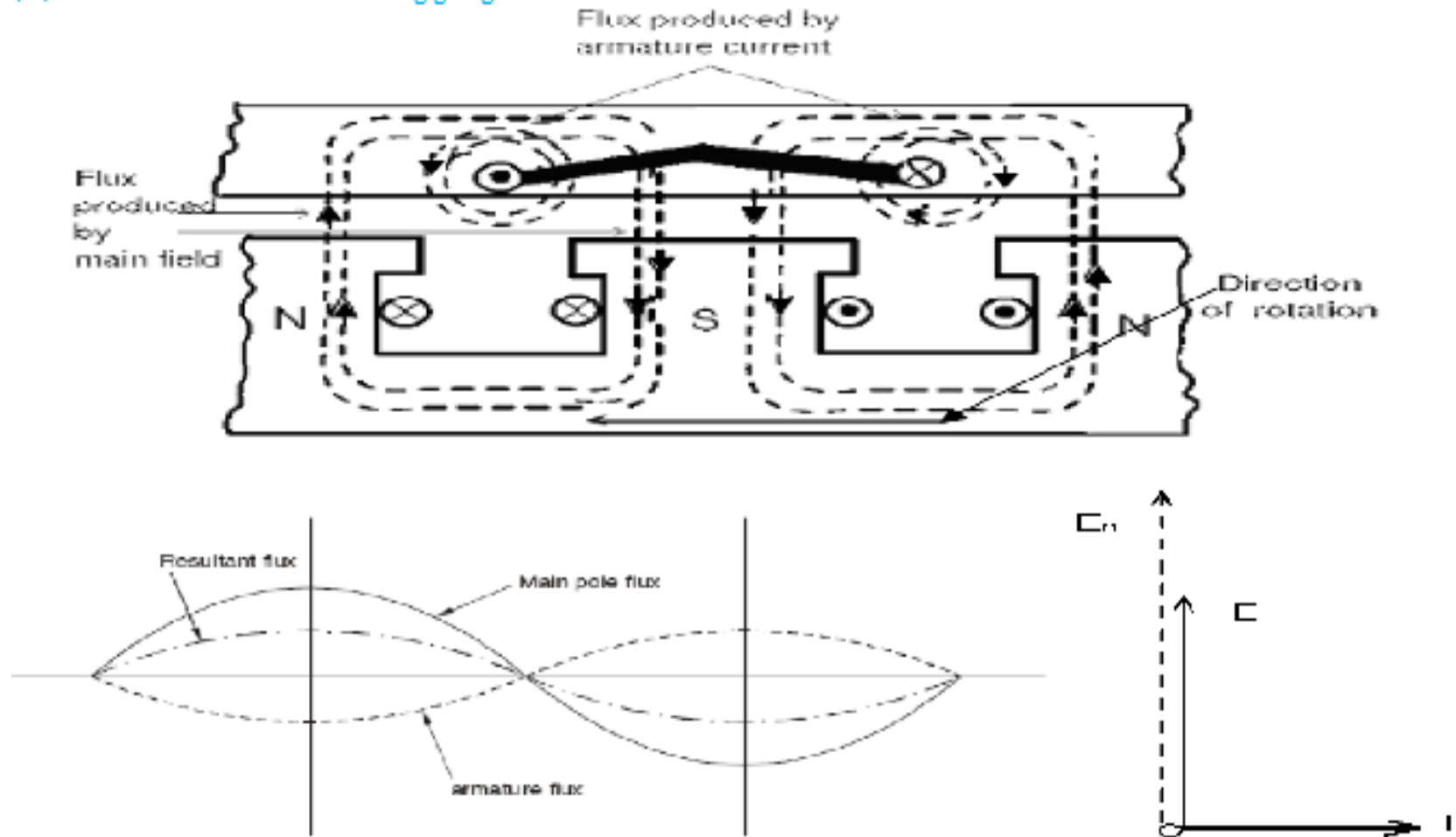

(c) Zero Power Factor Leading

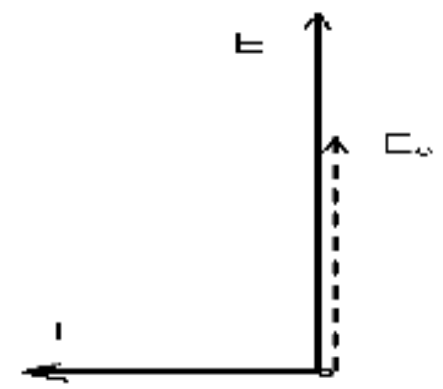
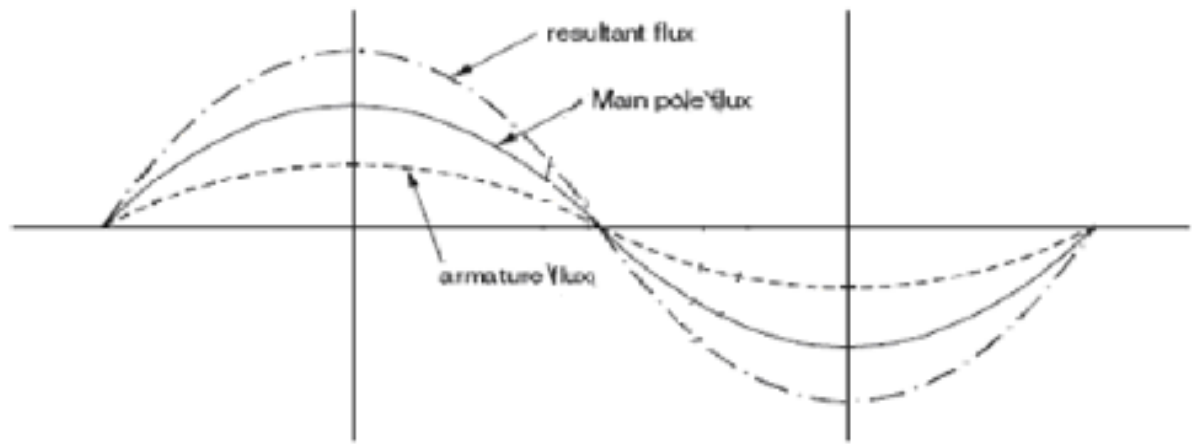
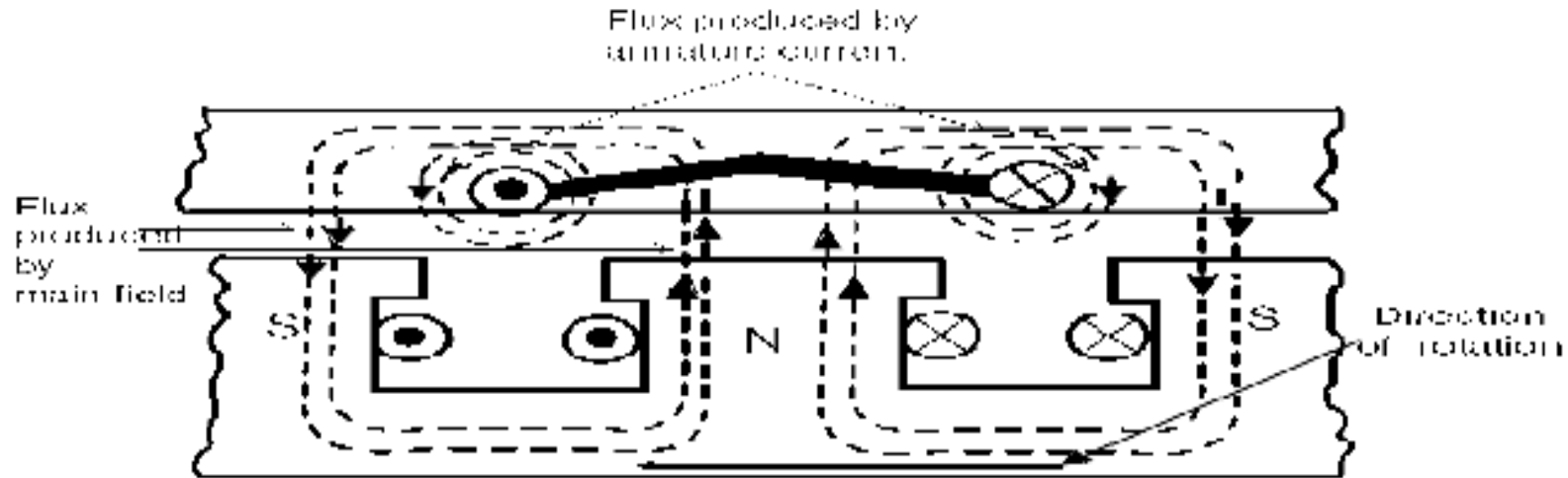

Phasor diagram

(i) Unity power factor load

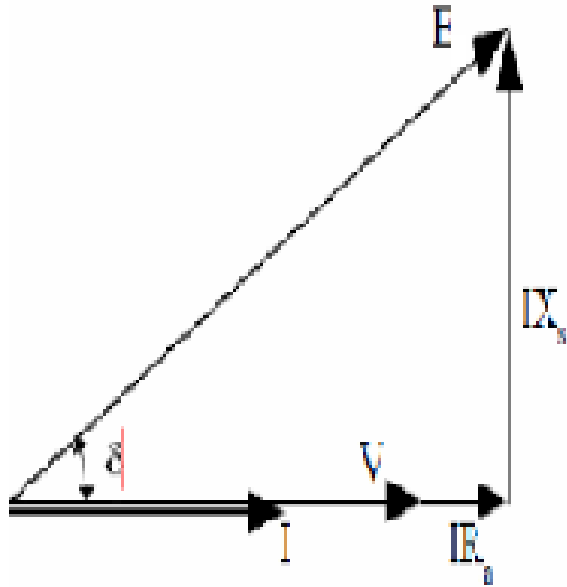

Under unity power factor load: $E_{ph} = (V + IR_a) + j (IX_s)$

$$E_{ph} = \sqrt{(V + IR_a)^2 + (IX_s)^2}$$

Zero power factor lagging

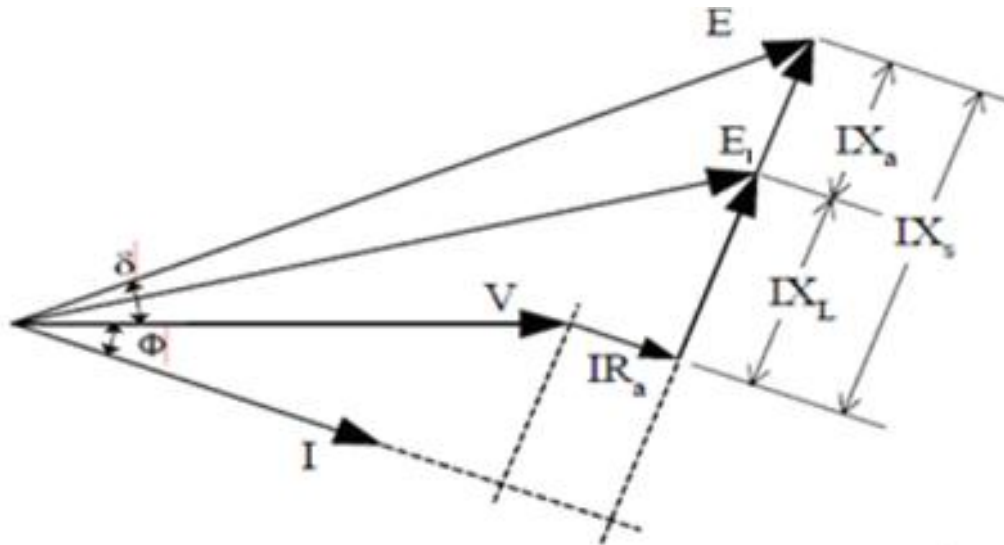

Under zero power factor lagging: $E_{ph} = V + (IR_a + j IX_s) = V + I(R_a + j X_s)$

The above expression can also be written as $E_{ph} = \sqrt{[(V \cos \delta + IR_a)^2 + (V \sin \delta + IX_s)^2]}$

Zero power factor leading

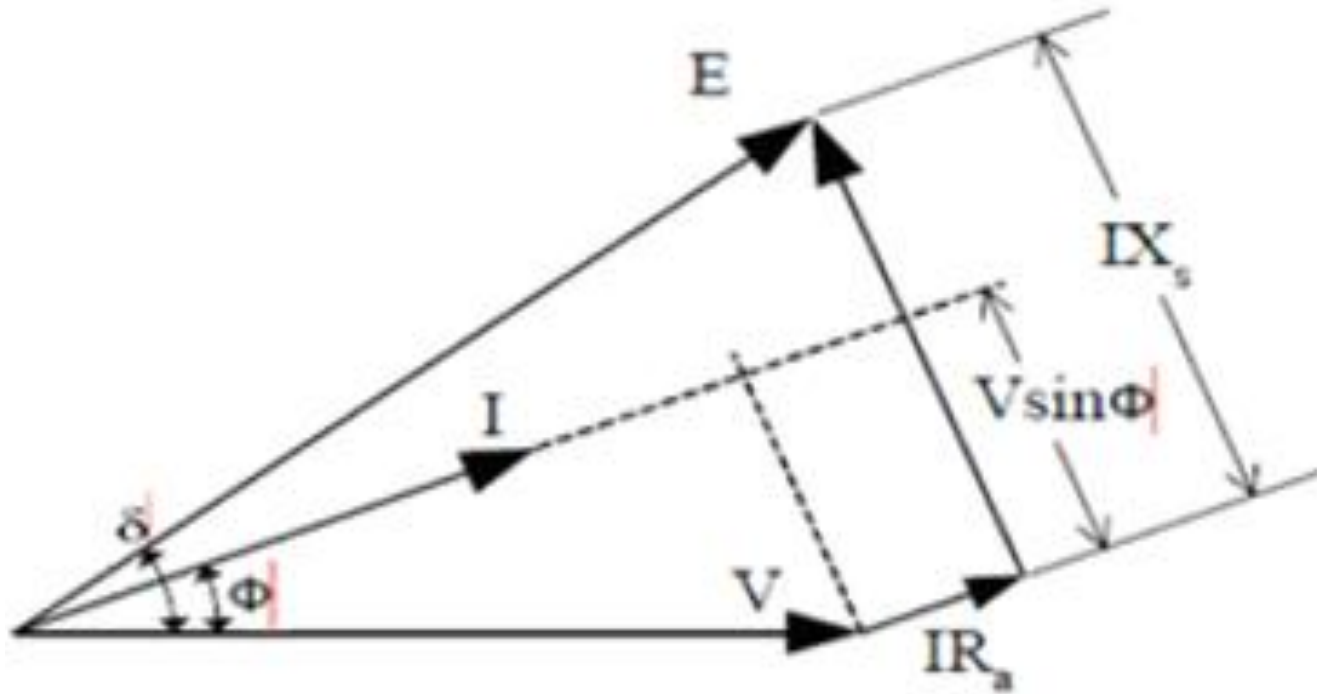

Numerical problems on windings

1. A 3Φ , 50 Hz, star connected salient pole alternator has 216 slots with 5 conductors per slot. All the conductors of each phase are connected in series; the winding is distributed and full pitched. The flux per pole is 30 mwb and the alternator runs at 250 rpm. Determine the phase and line voltages of EMF induced.

Slon: $N_s = 250$ rpm, $f = 50$ Hz,

$$P = 120 \times f / N_s = 120 \times 50 / 250 = 24 \text{ poles}$$

$$m = \text{number of slots/pole/phase} = 216 / (24 \times 3) = 3$$

$\beta = 1800 / \text{number of slots/pole} = 1800 / (216/24) = 200$ Hence distribution factor

$$\begin{aligned} K_d &= (\sin m\beta/2) / (m \sin \beta/2) \\ &= (\sin 3 \times 20 / 2) / (3 \sin 20/2) \\ &= 0.9597 \end{aligned}$$

Pitch factor $K_p = 1$ for full pitched winding. We have EMF induced per conductor

$$T_{ph} = Z_{ph} / 2 ; \quad Z_{ph} = Z / 3$$

$Z = \text{conductor/ slot} \times \text{number of slots}$ $T_{ph} = Z/6 = 216 \times 5 / 6 = 180$

Therefore $E_{ph} = 4.44 K_p K_d f \Phi T_{ph}$ volts

$$= 4.44 \times 1 \times 0.9597 \times 50 \times 30 \times 10^{-3} \times 180 = 1150.488 \text{ volts}$$

Hence the line Voltage $E_L = \sqrt{3} \times \text{phase voltage} = \sqrt{3} E_{ph} = \sqrt{3} \times 1150.488 = 1992.65 \text{ volts}$

- A 3Φ , 16 pole, star connected salient pole alternator has 144 slots with 10 conductors per slot. The alternator is run at 375 rpm. The terminal voltage of the generator found to be 2.657 KV. Determine the frequency of the induced EMF and the flux per pole
- A 4 pole, 3 phase, 50 Hz, star connected alternator has 60 slots with 4 conductors per slot. The coils are short pitched by 3 slots. If the phase spread is 60° , find the line voltage induced for a flux per pole of 0.943 wb.

Numerical problems on Windings

1. In a 3 phase star connected alternator, there are 2 coil sides per slot and 16 turns per coil. The stator has 288 slots. When run at 250 rpm the line voltage is 6600 volts at 50 Hz. The coils are short pitched by 2 slots. Calculate the flux per pole.

Soln: $N_s = 250$ rpm, $f = 50$ Hz, slots = 288, $E_L = 6600$ volts, 2 coil sides/slot,

- 16 turns /coil Short pitched by 2 slots
- Number of poles = $120f / N_s = 120 \times 50 / 250 = 24$
- Number of slots /pole/phase $m = 288 / (24 \times 3) = 4$
- Number of slots /pole = $288 / 24 = 12$
- Slot angle $\beta = 180 / \text{number of slots per pole} = 180 / 12 = 15^\circ$
- Distribution factor $k_d = (\sin m\beta/2) / (m \sin\beta/2)$
- $= \sin (4 \times 15/2) / 4 \sin(15/2)$
- $= 0.9576$
- Coils are short chorded by 2 slots Slot angle = 15°

Therefore coil is short pitched by $\alpha = 2 \times \text{slot angle} = 2 \times 15 = 30^\circ$

Hence pitch factor $K_p = \cos \alpha/2 = \cos 30/2 = 0.9659$

Two coil sides per slot and 16 turns per coil

Total number of conductors per slot = $2 \times 16 = 32$ turns
Total conductors = 32×288

Turns per phase = $32 \times 288 / 6 = 1536$

$E_{ph} = 6600 / \sqrt{3} = 3810.51$ volts,

We have EMF induced per phase $E_{ph} = 4.44 k_p k_d f \Phi T_{ph}$ volts

$3810.51 = 4.44 \times 0.9659 \times 0.9576 \times 50 \times \Phi \times 1536$

$\Phi = 0.02$ wb

2. A 10 pole, 600 rpm, 50Hz, alternator has the following sinusoidal flux density distribution. $B = \sin \theta + 0.4 \sin 3\theta + 0.2 \sin 5\theta$ wb/m². The alternator has 180 slots with 2 layer 3 turn coils with a coil span of 15 slots. The coils are connected in 600 groups. If the armature diameter is 1.2 m and core length is 0.4 m, calculate (a) the expression for instantaneous EMF/conductor (b) the expression for instantaneous EMF/coil (c) the phase and line voltages if the machine is star connected.
3. A three phase 600 kVA, 400 volts, delta connected alternator is reconnected in star. Calculate its new ratings in terms of voltage, current and volt-ampere.

Voltage Regulation

- Voltage regulation of an alternator is defined as the change in terminal voltage from no load to full load expressed as a percentage of rated voltage when the load at a given power factor is removed with out change in speed and excitation.

$$\% \text{ Regulation} = (E_{ph} - V_{ph} / V_{ph}) \times 100$$

where E_{ph} = induced EMF /phase, V_{ph} = rated terminal voltage/phase

different methods used for predetermination of regulation of alternators.

- Direct loading method
- EMF method or Synchronous impedance method
- MMF method or Ampere turns method
- ASA modified MMF method
- ZPF method or Potier triangle method
-

- This method is also known as synchronous impedance method. Here the magnetic circuit is assumed to be unsaturated. In this method the MMFs (fluxes) produced by rotor and stator are replaced by their equivalent EMF, and hence called EMF method.
- To predetermine the regulation by this method the following information's are to be determined. Armature resistance /phase of the alternator, open circuit and short circuit characteristics of the alternator.

OC & SC test on alternator

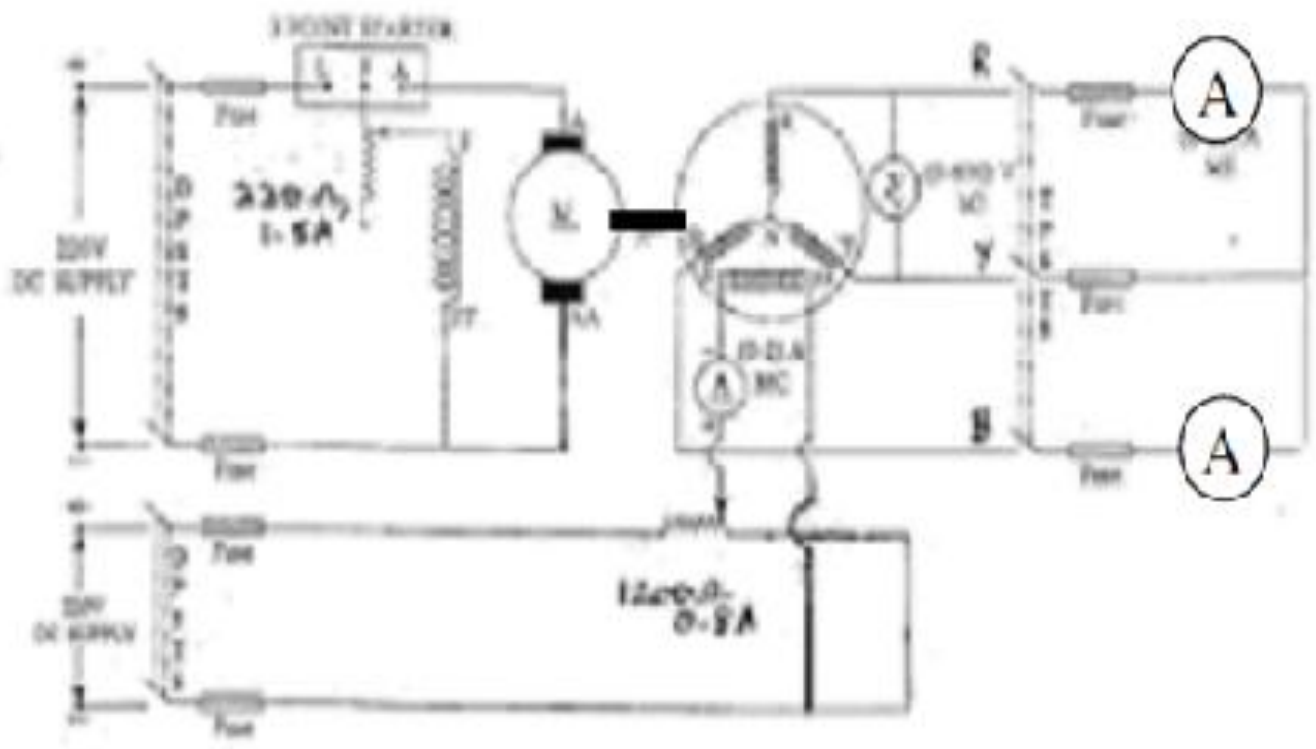

Procedure to conduct OC test:

- Start the prime mover and adjust the speed to the synchronous speed of the alternator.
- Keep the field circuit rheostat in cut in position and switch on DC supply.
- Keep the TPST switch of the stator circuit in open position.
- Vary the field current from minimum in steps and take the readings of field current and stator terminal voltage, till the voltage read by the voltmeter reaches up to 110% of rated voltage. Reduce the field current and stop the machine.
- Plot of terminal voltage/ phase vs field current gives the OC curve.

Short Circuit Characteristic (S.C.C.):

- The short-circuit characteristic, as its name implies, refers to the behavior of the alternator when its armature is short-circuited. In a single-phase machine the armature terminals are short-circuited through an ammeter, but in a three-phase machine all three phases must be short-circuited. An ammeter is connected in series with each armature terminal, the three remaining ammeter terminals being short-circuited. The machine is run at rated speed and field current is increased gradually to I_{f2} till armature current reaches rated value. The armature short-circuit current and the field current are found to be proportional to each other over a wide range

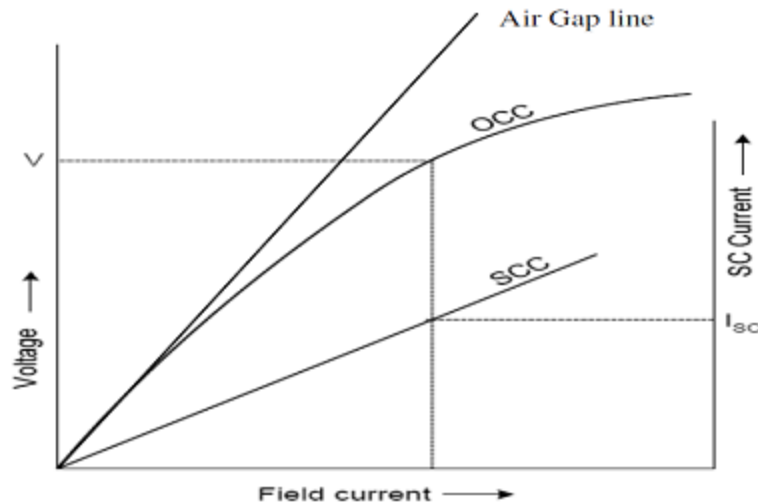

Short-Circuit Ratio:

The short-circuit ratio is defined as the ratio of the field current required to produce rated volts on open circuit to field current required to circulate full-load current with the armature short-circuited.

$$\text{Short-circuit ratio} = I_{f1}/I_{f2}$$

Determination of synchronous impedance

- Synchronous impedance $Z_s = (\text{open circuit voltage per phase}) / (\text{short circuit current per phase})$ for same I_f
- Hence $Z_s = (V_{oc}) / (I_{sc})$ for same I_f
- From figure 33 synchronous impedance $Z_s = V / I_{sc}$
- Armature resistance R_a of the stator can be measured using Voltmeter – Ammeter method. Using synchronous impedance and armature resistance synchronous reactance and hence regulation can be calculated as follows using EMF method
- $Z_s = \sqrt{(R_a)^2 + (X_s)^2}$ and Synchronous reactance $X_s = \sqrt{(Z_s)^2 - (R_a)^2}$

Hence induced EMF per phase can be found as

$$E_{ph} = \sqrt{(V \cos \theta + IR_a)^2 + (V \sin \theta \pm IX_s)^2}$$

where $V = \text{phase voltage per phase} = V_{ph}$, $I = \text{load current per phase}$

- In the above expression in second term + sign is for lagging power factor and – sign is for leading power factor.
- % Regulation = $[(E_{ph} - V_{ph} / V_{ph})] \times 100$
- Where E_{ph} = induced EMF /phase, V_{ph} = rated terminal voltage/phase
- Synchronous impedance method is easy but it gives approximate results. This method gives the value of regulation which is greater (poor) than the actual value and hence this method is called pessimistic method. The complete phasor diagram for the EMF method is shown in figure

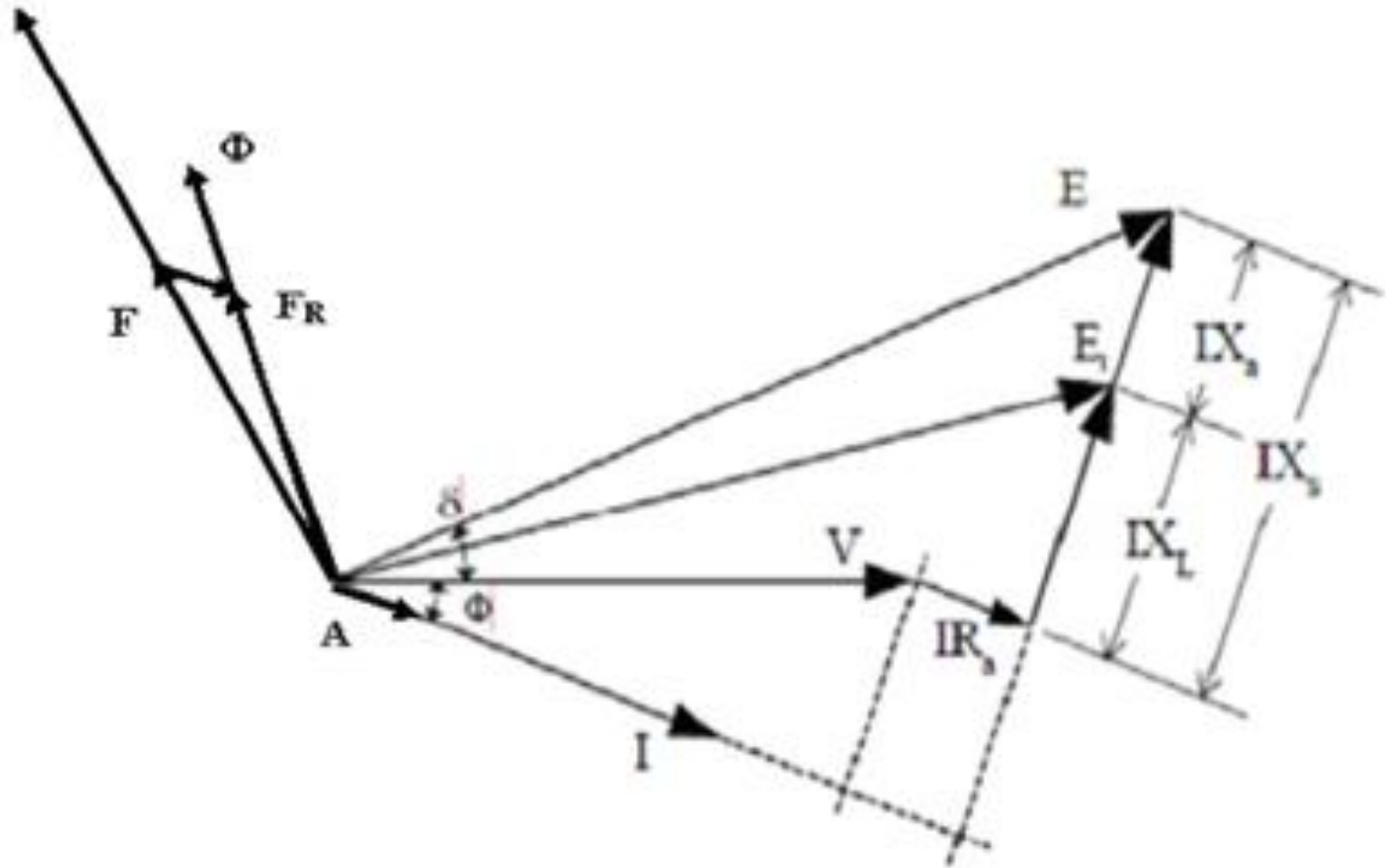

Numerical Problems on EMF method

1. 1A 1200 kVA, 3300 volts, 50 Hz, three phase star connected alternator has an armature resistance of 0.25Ω per phase. A field current of 40 Amps produces a short circuit current of 200 Amps and an open circuit EMF of 1100 volts line to line. Find the % regulation at full load 0.8 P.F lagging and leading by using EMF method.
2. A 10 MVA 6.6 kV, 3phase star connected alternator gave open circuit and short circuit data as follows.

Field current in amps:	25	50	75	100	125	150
OC voltage in kV (L-L):	2.4	4.8	6.1	7.1	7.6	7.9
SC Current in Amps:	288	528	875	-	-	-

Find the voltage regulation at full load 0.8 pf lagging by emf method.
 Armature resistance per phase = 0.13Ω .

MMF Method

- For any synchronous generator i.e. alternator, it requires MMF which is product of field current and turns of field winding for two separate purposes.
 1. It must have an MMF necessary to induce the rated terminal voltage on open circuit.
 2. It must have an MMF equal and opposite to that of armature reaction MMF

Note : In most of the cases as number of turns on the field winding is not known, the MMF is calculate and expressed i terms of the field current itself.

The field MMF required to induce the rated terminal voltage on open circuit can be obtained from open circuit test results and open circuit characteristics. This is denoted as F_o .

- Under short circuit condition as resistance and leakage reactance of armature do not play any significant role, the armature reaction reactance is dominating and hence the power factor of such purely reactive circuit is zero lagging. Hence F_{AR} gives demagnetizing ampere turns. Thus the field MMF is entirely used to overcome the armature reaction which is wholly demagnetizing in nature
- The two components of total field MMF which are F_O and F_{AR} are indicated in O.C.C. (open circuit characteristics) and S.C.C. (short circuit characteristics) as shown in the Fig.36

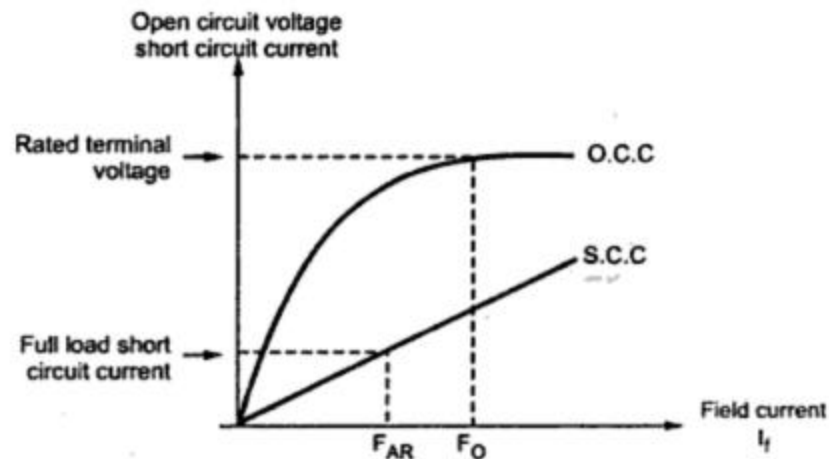

- If the alternator is supplying full load, then total field MMF is the vector sum of its two components F_O and F_{AR} . This depends on the power factor of the load which alternator is supplying. The resultant field MMF is denoted as F_R . Let us consider the various power factors and the resultant F_R .

Zero lagging P.f: As long as power factor is zero lagging, the armature reaction is completely demagnetizing. Hence the resultant F_R is the algebraic sum of the two components F_O and F_{AR} . Field MMF is not only required to produce rated terminal voltage but also required to overcome completely demagnetizing armature reaction effect.

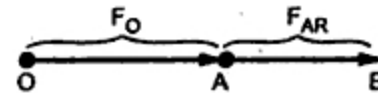

$$OA = F_O$$

$$AB = F_{AR} \text{ demagnetizing}$$

$$OB = F_R = F_O + F_{AR}$$

Total field MMF is greater than F_O .

Zero leading P.f: When the power factor is zero leading then the armature reaction is totally magnetizing and helps main flux to induce rated terminal voltage. Hence net field MMF required is less than that required to induce rated voltage normally, as part of its function is done by magnetizing armature reaction component. The net field MMF is the algebraic difference between the two components F_O and F_{AR} .

$$OA = F_O$$

$$AB = F_{AR} \text{ magnetizing}$$

$$OB = F_O - F_{AR} = F_R$$

Total MMF is less than F_O

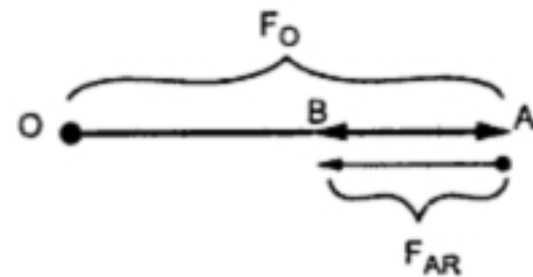

Unity P.f: Under unity power factor condition, the armature reaction is cross magnetizing and its effect is to distort the main flux. Thus F and F_{AR} are at right angles to each other and hence resultant MMF is the vector sum of F_O and F_{AR} .

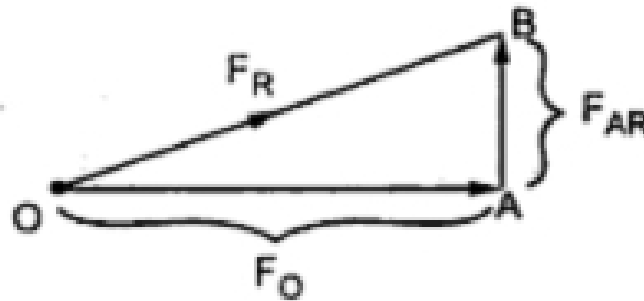

$$OA = F_O$$

$$AB = F_{AR} \text{ cross magnetizing}$$

- **General Case:** Now consider that the load power factor is $\cos \Phi$. In such case, the resultant MMF is to be determined by vector addition of F_O and F_{AR} .
- **Lagging P.f.:** When the load P.f. is $\cos \Phi$ lagging, the phase current I_{aph} lags V_{ph} by angle Φ . The component F_O is at right angles to V_{ph} while F_{AR} is in phase with the current I_{aph} .
- This is because the armature current I_{aph} decides the armature reaction. The armature reaction F_{AR} due to current I_{aph} is to be overcome by field MMF. Hence while finding resultant field MMF, $-F_{AR}$ should be added to vectorially.
- This is because resultant field MMF tries to counterbalance armature reaction to produce rated terminal voltage. The phasor diagram is shown in the Fig.

From the phasor diagram the various magnitude are,

$$OA = F_O, AB = F_{AR}, OB = F_R$$

Consider triangle OCB which is right angle triangle. The F_{AR} is split into two parts as,

$$AC = F_{AR} \sin\Phi \text{ and } BC = F_{AR} \cos\Phi$$

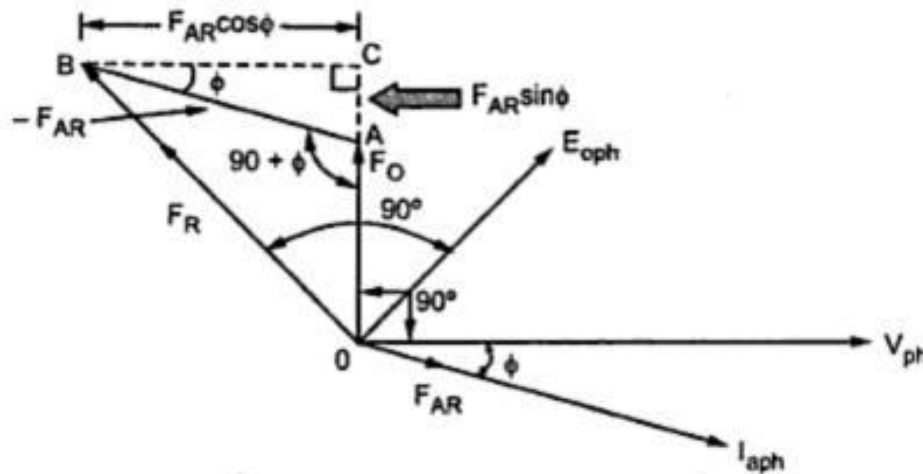

$$\therefore (F_R)^2 = (F_O + F_{AR} \sin\Phi)^2 + (F_{AR} \cos\Phi)^2 \dots\dots\dots (1)$$

From this relation (1), F_R can be determined.

Numerical Problems ASA Method

1. The following data pertains to a 15000 KVA, 11KV ,3-phase,50hz,star connected turbo-alternator:

Voc line (KV)	4.9	8.4	10.1	11.5	12.8	13.3	13.65
I_f (A)	10	18	24	30	40	45	50
ZPF full load line KV	-	0	-	-	-	102	-

Determine percentage regulation for full-load at 0.8 p.f. lagging by ASA method.

2. A 1000kVA, 11kV, 3 phase Y connected alternator has an effective resistance of 2Ω per phase. The OCC and ZPF lag characteristics for FL current are given below. Pre-determine the FL voltage regulation at 0.8p.f lag by ASA method

I_f (A)	20	25	55	70	90
OC Volt (kV)	6	7	12	13	14
V (kV) for ZPF	0	2	9	11	13

PARALLEL OPERATION OF ALTERNATORS

- The operation of connecting two alternators in parallel is known as synchronizing. Certain conditions must be fulfilled before this can be affected.
- **Reasons for operating in parallel:**
 - i) Handling larger loads.
 - ii) Maintenance can be done without power disruption.
 - iii) Increasing system reliability.
 - iv) Increased efficiency.

➤ **Conditions required for Paralleling:**

i) RMS line voltages must be equal.

ii) The generators to be paralleled must have the same phase sequence.

iii) The oncoming generator (the new generator) must have the same operating frequency as compared to the system frequency.

➤ **Advantages of Parallel Operating Alternators**

i) When there is maintenance or an inspection, one machine can be taken out from service and the other alternators can keep up for the continuity of supply.

ii) Load supply can be increased.

- iii)** During light loads, more than one alternator can be shut down while the other will operate in nearly full load.
- iv)** High efficiency.
- v)** The operating cost is reduced
- vi)** Ensures the protection of supply and enables cost-effective generation.
- vii)** The generation cost is reduced.
- viii)** Break down of a generator does not cause any interruption in the supply.
- ix)** Reliability of the whole power system increases.

➤ General Procedure for Paralleling Generators:

Consider the figure shown below. Suppose that generator G2 is to be connected to the running system as shown below:

1. Using Voltmeters, the field current of the oncoming generator should be adjusted until its terminal voltage is equal to the line voltage of the running system.
2. Check and verify phase sequence to be identical to the system phase sequence.

There are 2 methods to do this:

- i) One way is using the 3 lamp method, where the lamps are stretched across the open terminals of the switch connecting the generator to the system (as shown in the figure below). As the phase changes between the 2 systems, the lamps first get bright (large phase difference) and then get dim (small phase difference).

ii) If all 3 lamps get bright and dark together, then the systems have the same phase sequence. If the lamps brighten in succession, then the systems have the opposite phase sequence, and one of the sequences must be reversed

iii) Using a Synchroscope – a meter that measures the difference in phase angles (it does not check phase sequences only phase angles).

3. Check and verify generator frequency is same as that of the system frequency. This is done by watching a frequency of brightening and dimming of the lamps until the frequencies are close by making them to change very slowly

4. Once the frequencies are nearly equal, the voltages in the 2 systems will change phase with respect to each other very slowly. The phase changes are observed, and when the phase angles are equal, the switch connecting the 2 systems is closed.

THREE DARK LAMPS METHOD

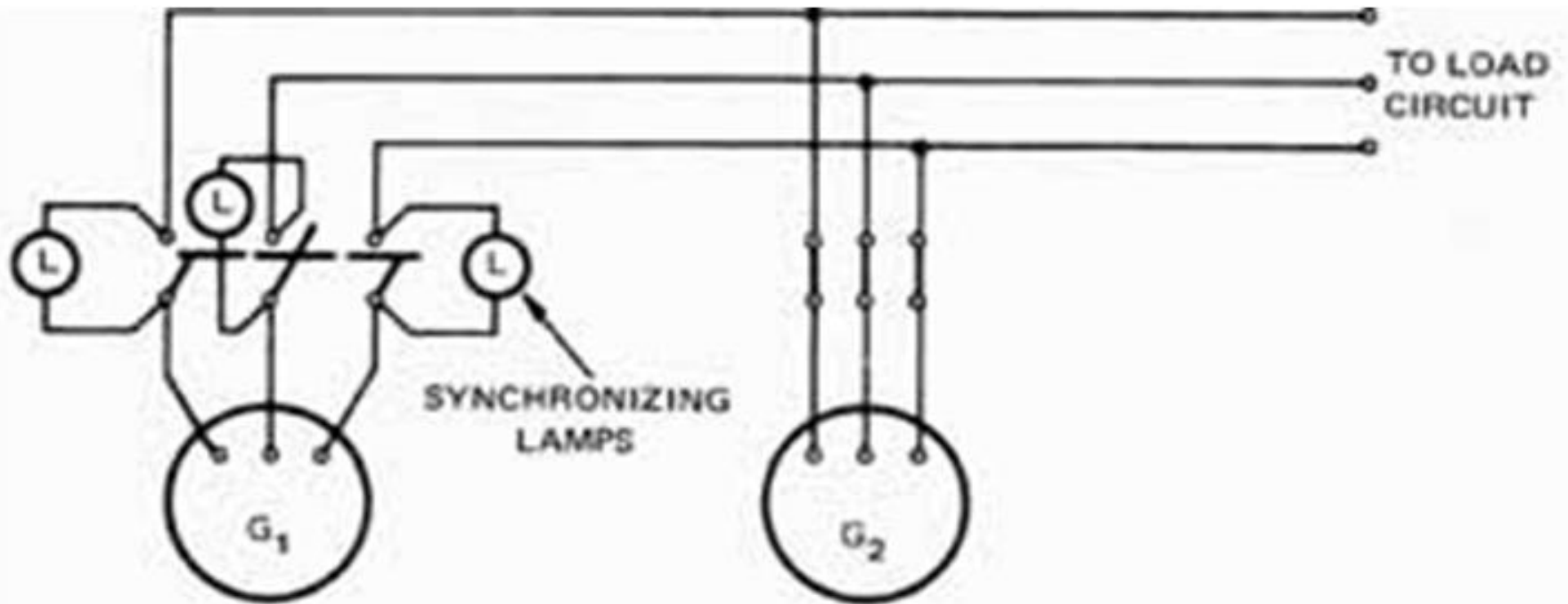

Fig. 3.8 Circuit for three dark lamps method

- The following describes the method of synchronizing two alternators using the three-dark method.
- When both machines are operating, one of two effects will be observed:
 - 1. The three lamps will light and go out in unison at a rate which depends on the difference in frequency between the two alternators.
- The three lamps will light and go out at a rate which depends on the difference in frequency between the two machines, but not in unison. In this case, the machines are not connected in the proper phase sequence and are said to be out of phase. To correct this, it's necessary to interchange any two leads to alternator G1.

➤ The machines are not paralleled until all lamps light and go out in unison.

The lamp method is shown for greater simplicity of operation.

➤ By making slight adjustments in the speed of alternator G1 the frequency of the machines can be equalized so that the synchronizing lamps will light and go out at the lowest possible rate. When the three lamps are out, the instantaneous electrical polarity of the three leads from G1 is the same as that of G2. At this instant, the voltage of G1 is equal to and in phase with that of G2. Now the paralleling switch can be closed so that both alternators supply power to the load. The two alternators are in synchronism, according to the three dark lamps method.

Two Bright, One Dark Lamp Method

- Another method of synchronizing alternators is the two bright, one dark method. In this method, any two connections from the synchronizing lamps are crossed after the alternators are connected and tested for the proper phase rotation. (The alternators are tested by the three dark method Fig. 3.9(A) shows the connections for establishing the proper phase rotation by the three dark method. Fig. 3.9(B) shows the lamp connections required to synchronize the alternator by the two bright, one dark method.

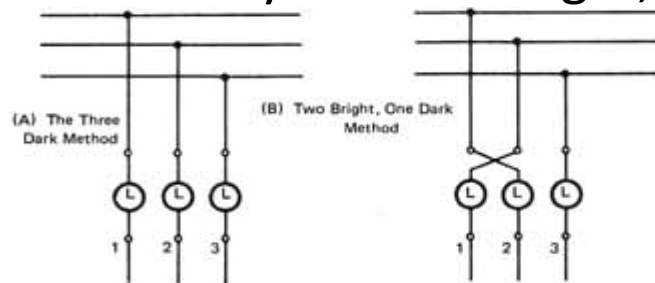

Fig. 3.9 (A) The Three-Dark Lamp Method; (B) Two-Bright, One-Dark Lamp Method

- When the alternators are synchronized, lamps 1 and 2 are bright and lamp 3 is dark. Since two of the lamps are becoming brighter as one is dimming, it's easier to determine the moment when the paralleling switch can be closed. Furthermore, by observing the sequence of lamp brightness, it's possible to tell whether the speed of the alternator being synchronized is too slow or too fast.

Synchronizing Power and Torque Coefficient



- Definition: – Synchronizing Power is defined as the varying of the synchronous power P on varying in the load angle δ . It is also called Stiffness of Coupling, Stability or Rigidity factor. It is represented as P_{syn} .
- The measure of effectiveness is given by **Synchronizing Power Coefficient**

$$P_{\text{syn}} = \frac{dP}{d\delta} \text{ ----- (1)}$$

Power output per phase of the cylindrical rotor generator

$$P = [E \cos (\theta_z - \delta) V \cos \theta_z] \text{ ----- (2)}$$

$$P_{\text{syn}} = \frac{dP}{d\delta} = \frac{VE}{Z_s} \sin (\theta_z) \text{ ----- (3)}$$

Synchronizing Torque Coefficient

The synchronizing torque coefficient

$$T_{syn} = \frac{dT}{d\delta} \frac{1}{2\pi ns} \frac{dP}{d\delta} \text{ ----- (4)}$$

$$T_{syn} = \frac{VE}{2\pi ns} \sin(\theta_z) \text{ ----- (5)}$$

- Synchronizing Torque Coefficient gives rise to the synchronizing torque coefficient at synchronous speed. That is, the Synchronizing Torque is the torque which at synchronous speed gives the synchronizing power. If T_{syn} is the synchronizing torque coefficient than the equation is given as shown below

$$T_{\text{syn}} = \frac{1}{\omega_s} m \frac{dP}{d\delta} \times \frac{P\pi}{180} \quad \text{Nm/ Electrical radian} \text{ ----- (6)}$$

$$T_{\text{syn}} = \frac{1}{\omega_s} m \frac{dP}{d\delta} \quad \text{Nm/ Electrical radian} \text{ ----- (7)}$$

- Where,

m is the number of phases of the machine

$$\omega_s = 2 \pi n_s$$

n_s is the synchronous speed in revolution per second

Load Sharing of Alternators

- When several alternators are required to run in parallel, it probably happens that their rated outputs differ. In such cases it is usual to divide the total load between them in such a way that each alternator takes the load in the same proportion of its rated load in total rated outputs. The total load is not divided equally. Alternatively, it may be desired to run one large alternator permanently on full load, the fluctuations in load being borne by one or more of the others.
- If the alternators are sharing the load equally the power triangles are as shown in figure below

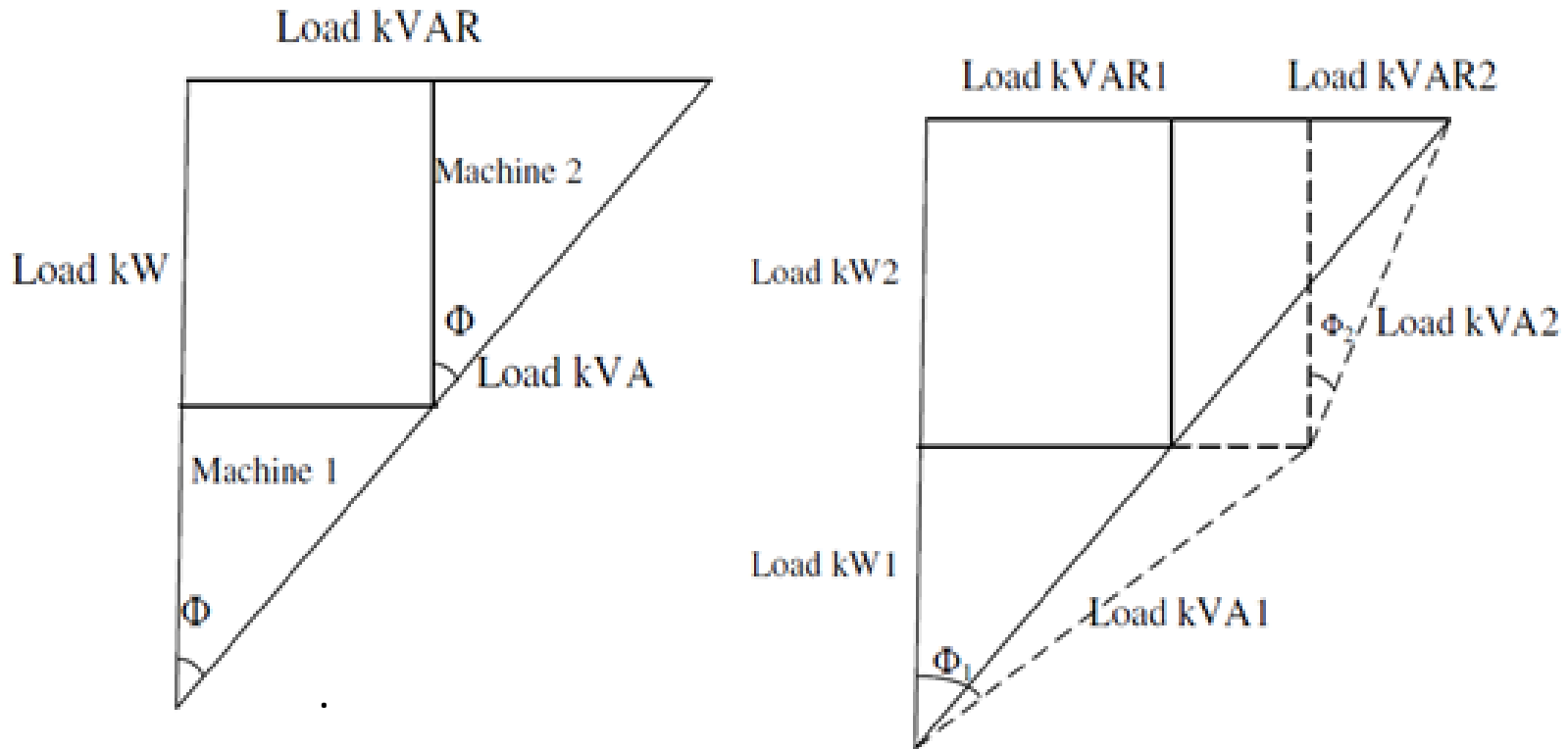

Figure: 3.12. Load sharing of alternators.

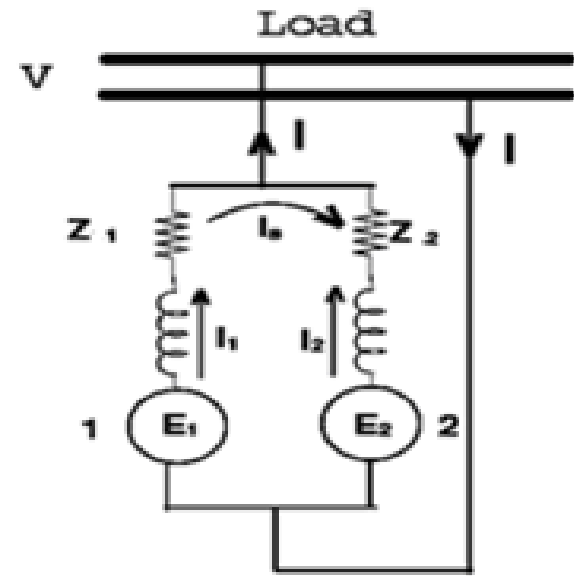
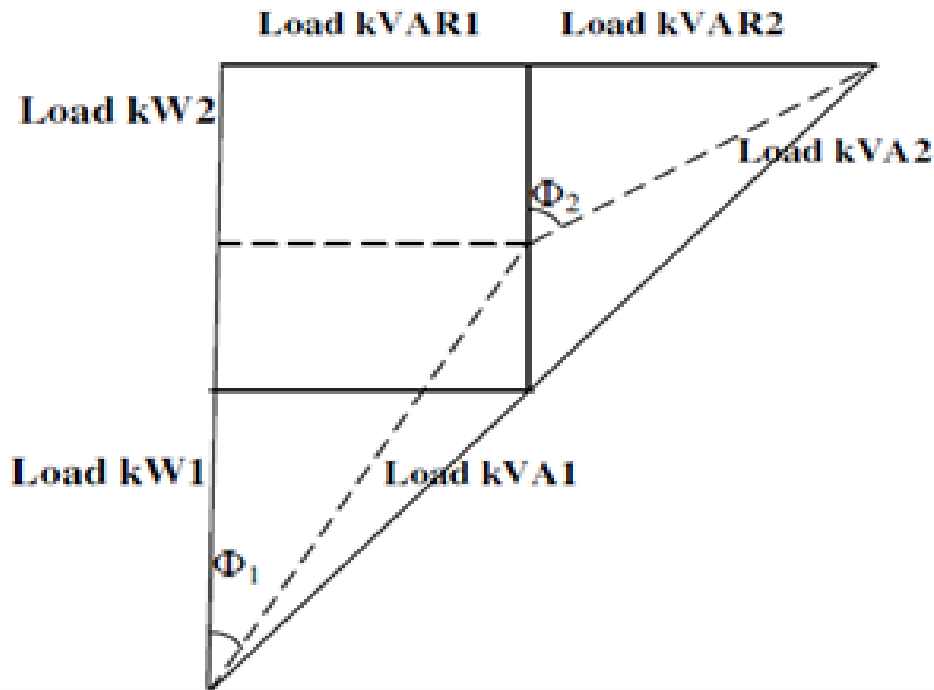

Figure: 3.13. Load sharing of alternators.

- Consider two alternators with identical speed load characteristics connected in parallel as shown in figure above.
- Let E_1, E_2 be the induced EMF per phase,
- Z_1, Z_2 be the impedances per phase
- I_1, I_2 be the current supplied by each machine per phase
- Z be the load impedance per phase,
- V be the terminal voltage per phase
- From the circuit we have $V = E_1 - I_1Z_1 = E_2 - I_2Z_2$ and hence

$$I_1 = \frac{E_1 - V}{Z_1} \quad I_2 = \frac{E_2 - V}{Z_2}$$

And also $V = (I_1 + I_2) Z = IZ$ solving above equations

$$I_1 = \frac{\left[\frac{(E_1 - E_2)}{Z} + E_1 Z_2 \right]}{[Z(Z_1 + Z_2) + Z_1 Z_2]}$$

$$I_2 = \frac{\left[\frac{(E_2 - E_1)}{Z} + E_2 Z_1 \right]}{[Z(Z_1 + Z_2) + Z_1 Z_2]}$$

Then total current is given by

$$I = I_1 + I_2 = \frac{[E_1 Z_2 + E_2 Z_1]}{[Z(Z_1 + Z_2) + Z_1 Z_2]}$$

And the circulating current or synchronizing current

$$I_{sy} = \frac{[E_1 - E_2]}{(Z_1 + Z_2)}$$

Numerical Problems on Load sharing

1. Two alternators working in parallel supply following loads i) Lighting load of 500 KW ii) 1000 KW at 0.9 p.f. lagging iii) 500 KW at 0.95 p.f. lead iv) 800 KW at 0.8 lagging. One alternator is supplying 1500 KW at 0.95 p.f. lagging. Calculate the load on the other machine.

Sol: The KW and KVAR components of each load are as follows. For lagging loads KVAR is considered positive whereas for leading loads KVAR is considered negative

Load	KW	cos	tan	KVAR = KW tan
1	500	1	0	0
2	1000	0.9 lag	0.4843	1000 0.4843 484.30
3	500	0.9 lead	0.4843	500 0.4843 - 242.15
4	800	0.8 lab	0.75	800 0.75 600

- Total KW = 500 + 1000 + 500 + 800 = 2800
- Total KVAR = 0 + 484.30 – 242.15 + 600 = 842.15
- If Φ_{sc} is total p.f. angle of combined load
- $\tan\Phi_{sc} = \frac{KVAR}{KW} = \frac{842.15}{280}$
- One alternator is supplying 1500 KW at 0.95 p.f. lagging
- $\cos\Phi_1 = 0.95$, $\tan\Phi_1 = 0.3286$
- Reactive component (KVAR) of machine 1 = KW $\tan \Phi_1 = 1500 \times 0.3286$
= 492.9 KVAR
- Active component of machine 2 = Total KW component Active component
of machine 1 = 2800 – 1500
= 1300 KW

- Reactive component of machine 2 = Total KVAR component Reactive component of machine 1
- $= 842.15 - 492.9$
- $= 349.25 \text{ KVAR}$
- The p.f. of machine 2 can be calculated as,
- $\tan\Phi_1 = \frac{\text{KVAR Component of machine 2}}{\text{KW Component of machine 2}}$
- $\Phi_2 = 15.03^\circ$
- Power factor = $\cos \Phi_2 = 0.9657 \text{ lag}$
- Output of machine 2 = 1300 KW
- Power factor of machine 2 = 0.9657 lagging

2. Two exactly similar turbo alternators are rated at 25 MW each. They are running in parallel. The speed load characteristics of the driving turbines are such that the frequency of alternator 1 drops uniformly from 50 Hz on no load to 48 Hz on full load and that of alternator 2 from 50 Hz to 48.5 Hz. How will they share a total load of 30 MW
3. Two identical 400 KVA alternators operate in parallel. The governor of the prime mover of first machine is such that the frequency drops uniformly from 50Hz on no load to 48 Hz on full load. The corresponding speed drop of the second machine is 50 Hz to 47.5 Hz. Find i) how will the two machines share a load of 6000 KW? ii) What is the maximum load of unity power factor that can be delivered without overloading either machine?

Numerical Problems on Load sharing

1. Two single phase alternators operating in parallel have induced EMFs on open circuit of 220 V and 220 V and respective reactance's of $j3\Omega$ and $j4\Omega$. Calculate i) Terminal voltage ii) Currents and iii) Power delivered by each of the alternators to a load of resistance 6Ω .

- Sol: Impedance of alternators 1, $Z_1 = j3\Omega$

- Impedance of alternator 2, $Z_2 = j4\Omega$

- $E_1 = 220\angle 0^\circ \text{ V}$

- $E_2 = 220\angle 0^\circ \text{ V}$

- Current I_1 is given by

- $$I_1 = \frac{(E_1 - E_2)Z + E_1Z_2}{Z(Z_1 + Z_2) + Z_1Z_2} = 14.90\angle 17.71$$

- $$I_2 = \frac{(E_2 - E_1)Z + E_2Z_1}{Z(Z_1 + Z_2) + Z_1Z_2}$$

- $I_2 = 20.36 \angle -7.23^\circ \text{ A}$
- $I = I_1 + I_2$
 $= (14.19 - j 4.53) + (20.19 - j 2.56)$
 $= 35.10 \angle -11.65^\circ$
- Now Voltage $V = IZ = (35.10 \angle -11.65^\circ) (6 \angle 0^\circ)$
 $= 210.6 \angle -11.65^\circ$
- $P_1 = VI_1 \cos \Phi_1 = 210.6 \cdot 14.90 \cos 7.23^\circ$
 $= 2989.22 \text{ Watts}$
- $P_2 = VI_2 \cos \Phi_2 = 210.6 \cdot 20.36 \cos 17.71^\circ = 4253.72 \text{ Watts}$

2. Two alternators running in parallel supply lighting load of 2500 KW and a motor load of 5000 KW at 0.707 P.F. one machine is loaded to 4000 KW at a P.F. of 0.8 lagging. What is the KW output and P.F. of the other machine?
3. Two single phase alternators operate in parallel and supply a load impedance of $(3 + j4) \Omega$. If the impedance of the machine is $(0.2 + j2)$ and EMFs are $(220 + j0)$ and $(220 + j0)$ volts respectively determine for each machine. i) Terminal voltage ii) Power factor and iii) Output

Numerical Problems on Load sharing

1. Two single phase alternators operating in parallel have induced EMFs on open circuit of $220\angle 0^\circ$ V and $220\angle 10^\circ$ V and respective reactance's of $j3\Omega$ and $j4\Omega$. Calculate i) Terminal voltage ii) Currents and iii) Power delivered by each of the alternators to a load of resistance 6Ω .

• Sol: Impedance of alternators 1, $Z_1 = j3\Omega$

Impedance of alternator 2, $Z_2 = j4\Omega$

$$E_1 = 220\angle 0^\circ \text{ V}$$

$$E_2 = 220\angle 10^\circ \text{ V}$$

Current I_1 is given by, I_1

$$= \frac{(E_1 - E_2)Z + E_1 Z_2}{Z(Z_1 + Z_2) + Z_1 Z_2}$$

$$I_1 = \frac{(220\angle 0^\circ - 220\angle 10^\circ)6 + (220\angle 10^\circ)j4}{6(j3 + j4) + (j3)(j4)} = 14.90\angle 17.71^\circ$$

$$I_2 = \frac{(E_2 - E_1)Z + E_2 Z_1}{Z(Z_1 + Z_2) + Z_1 Z_2} = \frac{(220 \angle 10^\circ - 220 \angle 0^\circ)6 + (220 \angle 10^\circ)j3}{6(j3 + j4) + (j3)(j4)}$$

$$I_2 = 20.36 \angle -7.23^\circ \text{ A}$$

$$\begin{aligned} I &= I_1 + I_2 \\ &= (14.19 - j 4.53) + (20.19 - j 2.56) \\ &= 35.10 \angle -11.65^\circ \end{aligned}$$

Now Voltage $V = IZ = (35.10 \angle -11.65^\circ)(6 \angle 0^\circ)$
 $= 210.6 \angle -11.65^\circ$

$$\begin{aligned} P_1 &= VI_1 \cos \Phi_1 = 210.6 \cdot 14.90 \cos 7.23^\circ \\ &= 2989.22 \text{ Watts} \end{aligned}$$

$$\begin{aligned} P_2 &= VI_2 \cos \Phi_2 = 210.6 \cdot 20.3 \cos 17.71^\circ \\ &= 4253.72 \text{ Watts} \end{aligned}$$

2. Two alternators running in parallel supply lighting load of 2500 KW and a motor load of 5000 KW at 0.707 P.F. one machine is loaded to 4000 KW at a P.F. of 0.8 lagging. What is the KW output and P.F. of the other machine?
3. Two single phase alternators operate in parallel and supply a load impedance of $(3 + j4) \Omega$. If the impedance of the machine is $(0.2 + j2)$ and EMFs are $(220 + j0)$ and $(220 + j0)$ volts respectively determine for each machine. i) Terminal voltage ii) Power factor and iii) Output



MODULE - IV

SYNCHRONOUS MOTOR

Synchronous motor Principle of operation

- The stator is wound for the similar number of poles as that of rotor, and fed with three phase AC supply. The 3 phase AC supply produces rotating magnetic field in stator. The rotor winding is fed with DC supply which magnetizes the rotor.
- Now, the stator poles are revolving with synchronous speed (let's say clockwise). If the rotor position is such that, N pole of the rotor is near the N pole of the stator (as shown in first schematic of above figure), then the poles of the stator and rotor will repel each other, and the torque produced will be anticlockwise.

- The stator poles are rotating with synchronous speed, and they rotate around very fast and interchange their position. But at this very soon, rotor cannot rotate with the same angle (due to inertia), and the next position will be likely the second schematic in above figure. In this case, poles of the stator will attract the poles of rotor, and the torque produced will be clockwise.
- Hence, the rotor will undergo to a rapidly reversing torque, and the motor will not start.

- But, if the rotor is rotated up to the synchronous speed of the stator by means of an external force (in the direction of revolving field of the stator), and the rotor field is excited near the synchronous speed, the poles of stator will keep attracting the opposite poles of the rotor (as the rotor is also, now, rotating with it and the position of the poles will be similar throughout the cycle). Now, the rotor will undergo unidirectional torque. The opposite poles of the stator and rotor will get locked with each other, and the rotor will rotate at the synchronous speed.

Characteristic features of a synchronous motor

- Synchronous motor will run either at synchronous speed or will not run at all.
- The only way to change its speed is to change its supply frequency. (As $N_s = 120f / P$)
- Synchronous motors are not self starting. They need some external force to bring them near to the synchronous speed.
- They can operate under any power factor, lagging as well as leading. Hence, synchronous motors can be used for power factor improvement.

Synchronous motor starting methods

The various methods to start the synchronous motor are,

1. Using pony motors
2. Using damper winding
3. As a slip ring induction motor
4. Using small DC. Machine coupled to it.

1. Using pony motors

In this method, the rotor is brought to the synchronous speed with the help of some external device like small induction motor. Such an external device is called 'pony motor'.

Once the rotor attains the synchronous speed, the d.c. excitation to the rotor is switched on. Once the synchronism is established pony motor is decoupled. The motor then continues to rotate as synchronous motor.

2. Using Damper Winding

In a synchronous motor, in addition to the normal field winding, the additional winding consisting of copper bars placed in the slots in the pole faces. The bars are short circuited with the help of end rings. Such an additional winding on the rotor is called damper winding. This winding as short circuited, acts as a squirrel cage rotor winding of an induction motor. The schematic representation of such damper winding is shown in the

Fig.48.

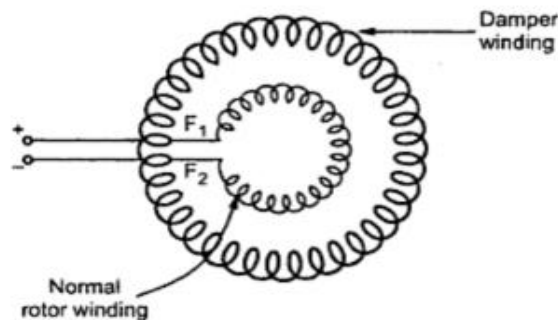

- Once the rotor is excited by a three phase supply, the motor starts rotating as an induction motor at sub synchronous speed. Then DC supply is given to the field winding. At a particular instant motor gets pulled into synchronism and starts rotating at a synchronous speed. As rotor rotates at synchronous speed, the relative motion between damper winding and the rotating magnetic field is zero. Hence when
- motor is running as synchronous motor, there cannot be any induced EMF in the damper winding. So damper winding is active only at start, to run the motor as an induction motor at start. Afterwards it is out of the circuit. As damper winding is short circuited and motor gets started as induction motor, it draws high current at start so induction motor starters like star-delta, autotransformer etc. used to start the synchronous motor as an induction motor.

Characteristic features of a synchronous motor

- Synchronous motor will run either at synchronous speed or will not run at all.
- The only way to change its speed is to change its supply frequency. (As $N_s = 120f / P$)
- Synchronous motors are not self starting. They need some external force to bring them near to the synchronous speed.
- They can operate under any power factor, lagging as well as leading. Hence, synchronous motors can be used for power factor improvement.

3. As a Slip Ring Induction Motor

- The above method of starting synchronous motor as a squirrel cage induction motor does not provide high starting torque. So to achieve this, instead of shorting the damper winding, it is designed to form a three phase star or delta connected winding. The three ends of this winding are brought out through slip rings. An external rheostat then can be introduced in series with the rotor circuit. So when stator is excited, the motor starts as a slip ring induction motor and due to resistance added in the rotor provides high starting torque. The resistance is then gradually cut off, as motor gathers speed. When motor attains speed near synchronous.
- DC excitation is provided to the rotor, then motor gets pulled into synchronism and starts rotating at synchronous speed. The damper winding is shorted by shorting the slip rings.

Contd..

- The initial resistance added in the rotor not only provides high starting torque but also limits high inrush of starting current. Hence it acts as a motor resistance starter.
- The synchronous motor started by this method is called a slip ring induction motor is shown in the Fig.49.

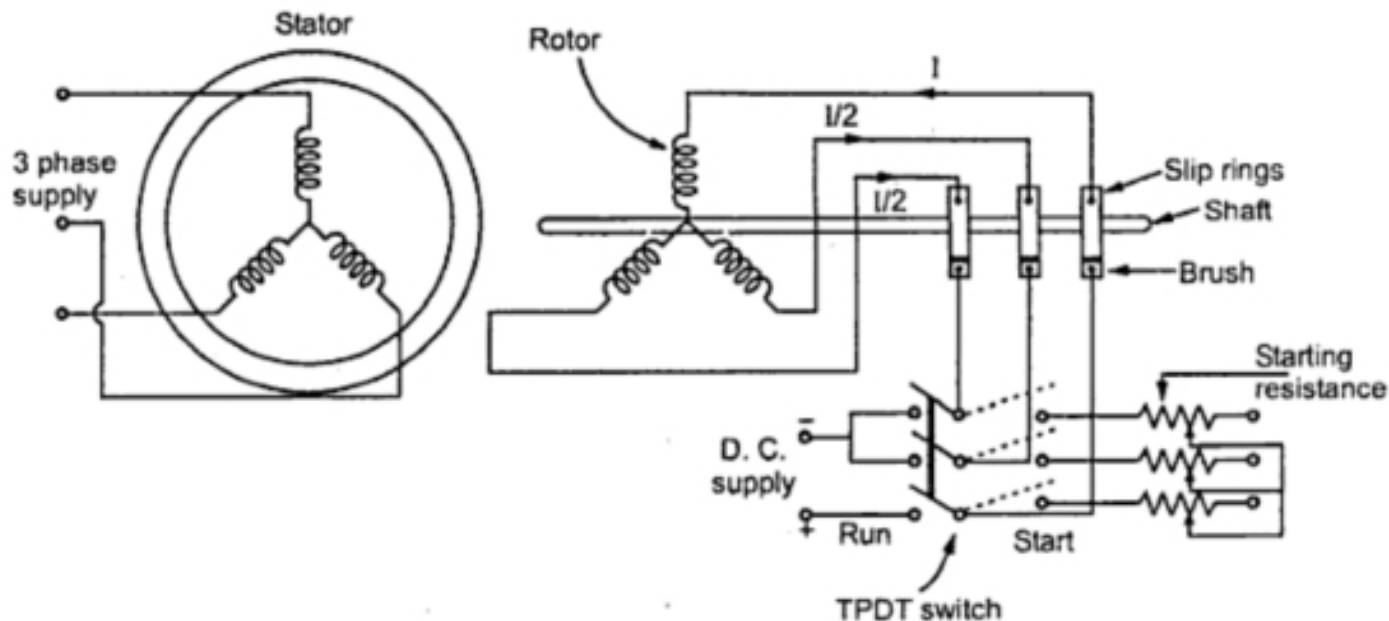

4. Using Small D.C. Machine

Many a times a large synchronous motor is provided with a coupled DC machine. This machine is used as a DC motor to rotate the synchronous motor at a synchronous speed. Then the excitation to the rotor is provided. Once motor starts running as a synchronous motor, the same DC machine acts as a DC generator called exciter. The field of the synchronous motor is then excited by this exciter itself.

Effect of changes in load on, I_a , δ , and p. f. of synchronous motor

- The effects of changes in mechanical or shaft load on armature current, power angle, and power factor can be seen from the phasor diagram shown in Figure below;
- As already stated, the applied stator voltage, frequency, and field excitation are assumed, constant. The initial load conditions are represented by the thick lines. The effect of increasing the shaft load to twice its initial value is represented by the light lines indicating the new steady state conditions.
- While drawing the phasor diagrams to show new steady-state conditions, the line of action of the new $jI_a X_s$ phasor must be perpendicular to the new I_a phasor. Furthermore, as shown in figure if the excitation is not changed, increasing the shaft load causes the locus of the E_f phasor to follow a circular arc, thereby increasing its phase angle with increasing shaft load.

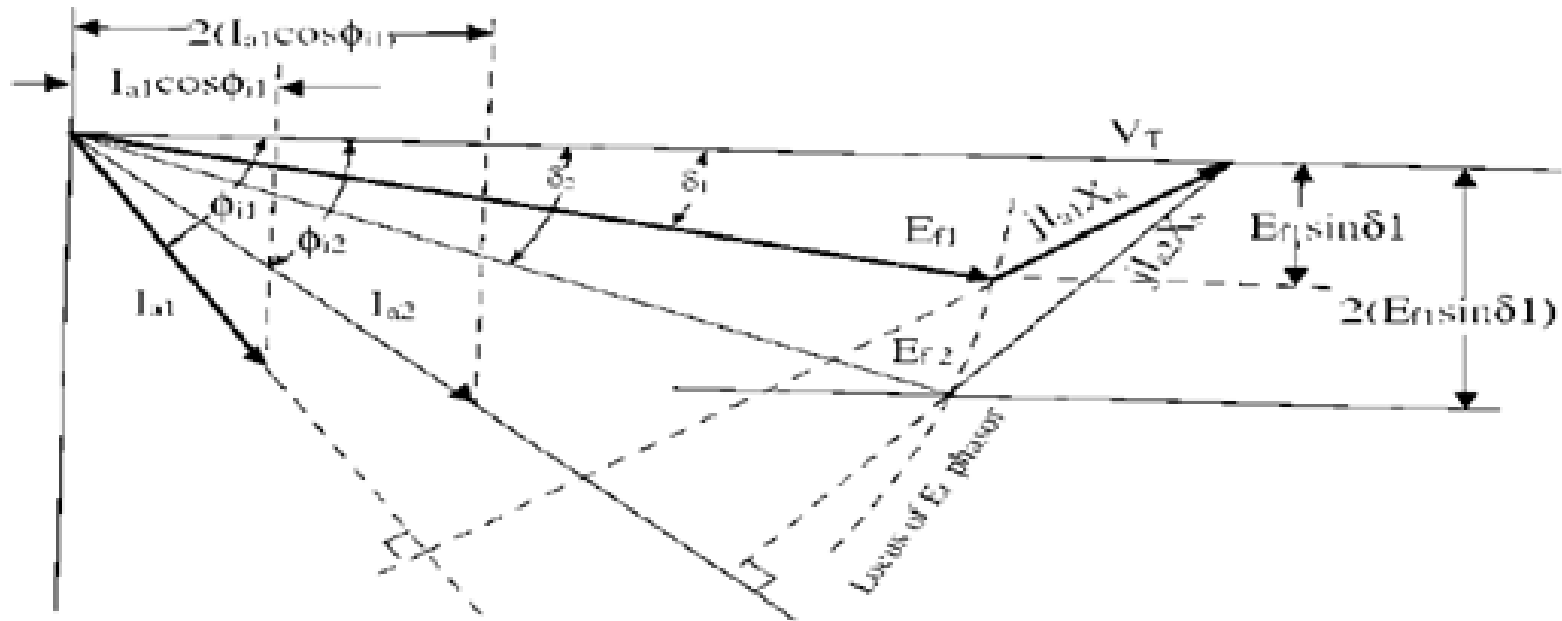

Figure: 50. Effect of changes in load on, I_a , δ , and p. f

Effect of changes in excitation on the performance synchronous motor



- Increasing the strength of the magnets will increase the magnetic attraction, and thereby cause the rotor magnets to have a closer alignment with the corresponding opposite poles of the rotating magnetic poles of the stator. This will obviously result in a smaller power angle.
- This fact can also be seen from power angle equation. When the shaft load is assumed to be constant, the steady-state value of $E_f \sin\delta$ must also be constant. An increase in E_f will cause a transient increase in $E_f \sin\delta$, and the rotor will accelerate. As the rotor changes its angular position, δ decreases until $E_f \sin\delta$ has the same steady-state value as before, at which time the rotor is again operating at synchronous speed, as it should run only at the synchronous speed.

- This change in angular position of the rotor magnets relative to the poles of rotating magnetic field of the stator occurs in a fraction of a second. The effect of changes in field excitation on armature current, power angle, and power factor of a synchronous motor operating with a constant shaft load, from a constant voltage, constant frequency supply, is illustrated in figure below
- $E_{f1} \sin \delta_1 = E_{f2} \sin \delta_2 = E_{f3} \sin \delta_3 = E_f \sin \delta$
- This is shown in Figure below, where the locus of the tip of the E_f phasor is a straight line parallel to the V_T phasor. Similarly,
- $I_{a1} \cos \Phi_{i1} = I_{a2} \cos \Phi_{i2} = I_{a3} \cos \Phi_{i3} = I_a \cos \Phi_i$
- This is also shown in Figure below, where the locus of the tip of the I_a phasor is a line perpendicular to the phasor V_T .

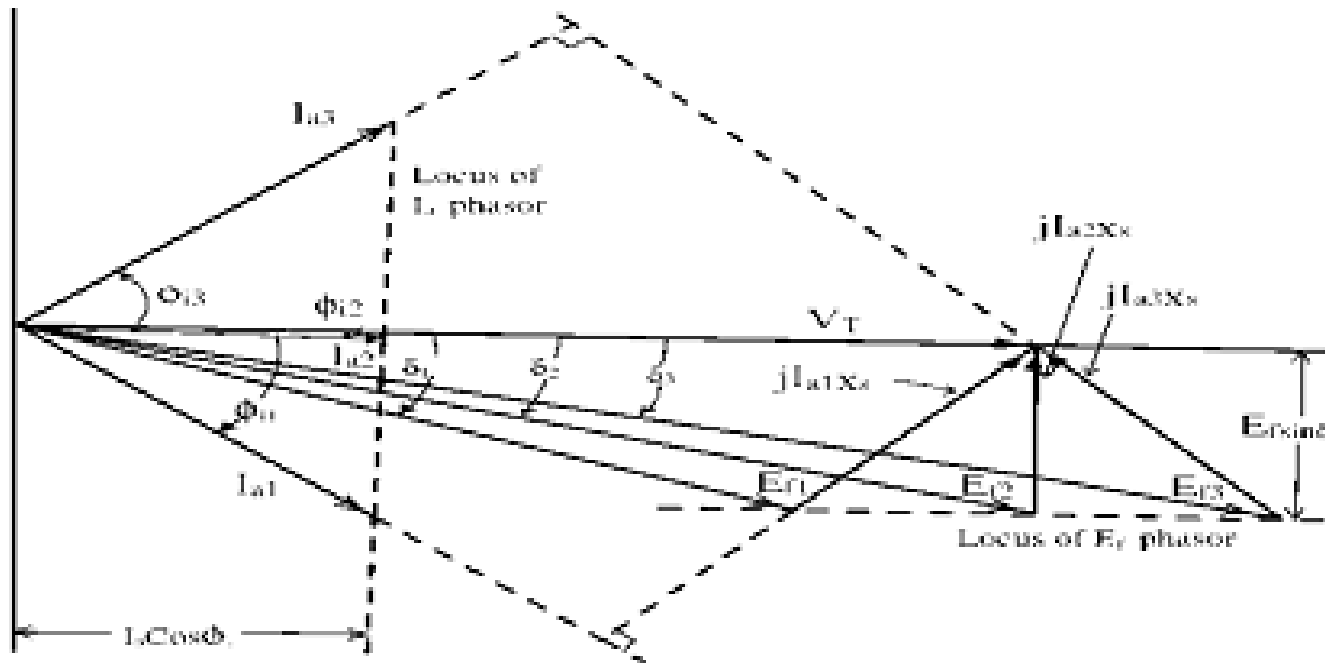
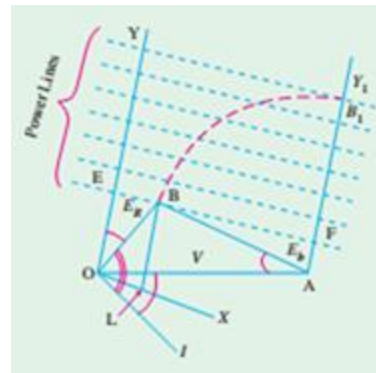

Figure: 51. Phasor diagram showing effect of changes in field excitation on armature current, power angle and power factor of a synchronous motor

Constant-power Lines

- In below fig, OA represents applied voltage / phase of the motor and AB is the back EMF./ phase, E_b . OB is their resultant voltage ER . The armature B current is OI lagging behind ER by an angle $\phi = \angle ERO$ or vector OB represents (to some suitable scale) the main current I .
- OY is drawn at an angle f with OB (or at an angle ϕ with CA). BL is drawn perpendicular to OX which is at right angles to OY . Vector OB , when referred to OY , also represents, on a different scale, the current both in magnitude and phase



- As V is constant, power input is dependent on $B L$. If motor is working with a constant intake, then locus of B is a straight line \parallel to OX and \perp to OY i.e. line EF for which BL is constant. Hence, EF represents a constant-power input line for a given voltage but varying excitation. Similarly, a series of such parallel lines can be drawn each representing a definite power intake of the motor. As regards these constant-power lines, it is to be noted that
 1. For equal increase in intake, the power lines are parallel and equally-spaced
 2. Zero power line runs along OX
 3. The perpendicular distance from B to OX (or zero power line) represents the motor intake

- If excitation is fixed i.e. AB is constant in length, then as the load on motor is increased, increases. In other words, locus of B is a circle with radius = AB and centre at A . With increasing load, B goes on to lines of higher power till point B_1 is reached.
- Any further increase in load on the motor will bring point B down to a lower line. It means that as load increases beyond the value corresponding to point B_1 , the motor intake decreases which is impossible.
- The area to the right of AY_1 represents unstable conditions. For a given voltage and excitation, the maximum power the motor can develop, is determined by the location of point B_1 beyond which the motor pulls out of synchronism.

- The circle represented by equation (1) has a centre at some point O' on the line OY . The circle drawn with centre as O' and radius as $O'B$ represents circle of constant power. This is called Blondel diagram, shown in the Fig. 2.
- Thus if excitation is varied while the power is kept constant, then working point B while move along the circle of constant power.

Let $O'B = \text{Radius of circle} = r$

$OO' = \text{Distant } d$

Applying cosine rule to triangle OBO' ,

- Now OB represents resultant ER which is $I_a Z_s$. Thus OB is proportional to current and when referred to OY represents the current in both magnitude and phase.

$OB = I_a = I$ say

Substituting various values in equation (2) we get,

$$r^2 = I^2 + d^2 - 2dI \cos \phi$$

$$I^2 - 2dI \cos \phi + (d^2 - r^2) = 0 \quad \dots (3)$$

Comparing equations (1) and (3) we get,

$$OO' = d = \frac{V}{2R_1} \quad \dots (4)$$

Thus the point O' is independent of power P_m and is a constant for a give motor operating at a fixed applied voltage V .

- Thus the point O' is independent of power P_m and is a constant for a give motor operating at a fixed applied voltage V .
- Comparing last term of equations (1) and (3),

$$\begin{aligned}
 d^2 - r^2 &= \frac{P_m}{R_a} \\
 r^2 &= \left(d^2 - \frac{P_m}{R_a} \right) \\
 r &= \sqrt{d^2 - \frac{P_m}{R_a}} \\
 &= \sqrt{\left(\frac{V}{2R_a} \right)^2 - \frac{P_m}{R_a}} \\
 \boxed{r} &= \frac{1}{2R_a} \sqrt{V^2 - 4P_m R_a}
 \end{aligned}$$

The equation shows that as power P_m must be real, then $4P_m R_a \leq V^2$. The maximum possible power per phase is

$$4 (P_m)_{\max} R_a = V^2$$

$$(P_m)_{\max} = \frac{V^2}{4 R_a}$$

... (6)

And the radius of the circle for maximum power is zero. Thus at the time of maximum power, the circles becomes a point O' . While when the power $P_m = 0$, then $r = V/2R_a = OO'$

This shows that the circle of zero power passes through the points O and A .

The radius for any power P_m is given by,

$$r = \frac{V}{2 R_a} \sqrt{1 - \frac{4 P_m R_a}{V^2}}$$

but $(P_m)_{\max} = \frac{V^2}{4 R_a}$, substituting above

$$r = \frac{V}{2 R_a} \sqrt{1 - \frac{P_m}{(P_m)_{\max}}}$$

$$\therefore r = \frac{V}{2 R_a} \sqrt{1 - m}$$

where $m = \frac{P_m}{(P_m)_{\max}}$

We know, $OO' = d = \frac{V}{2 R_a}$

$$\therefore r = d \sqrt{1 - m}$$

... (7)

Power flow i synchronous motor

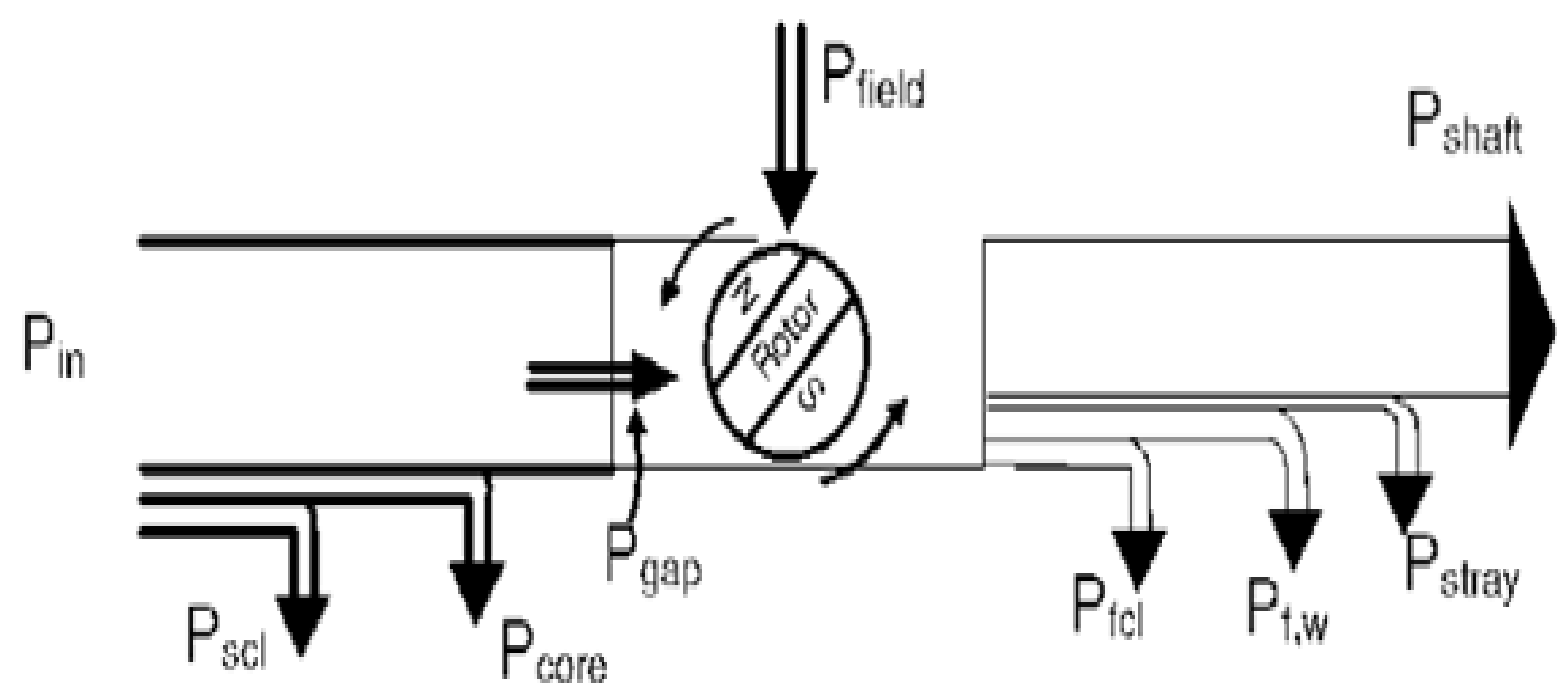

Where

- P_{in} = Power input to the motor
- P_{scl} = Power loss as stator copper loss P_{core} = Power loss as core loss
- P_{gap} = Power in the air gap
- P_{fcl} = Power loss as field copper loss
- P_{fw} = Power loss as friction and windage loss P_{stray} = Power loss as stray loss
- P_{shaft} = Shaft output of the machine
- Power input to a synchronous motor is given by $P = 3V_{ph}I_{ph}\cos\Phi = \sqrt{3}V_L I_L \cos\Phi$. In stator as per the diagram there will be core loss and copper losses taking place. The remaining power will be converted to gross mechanical power.
- Hence P_m = Power input to the motor – Total losses in stator.

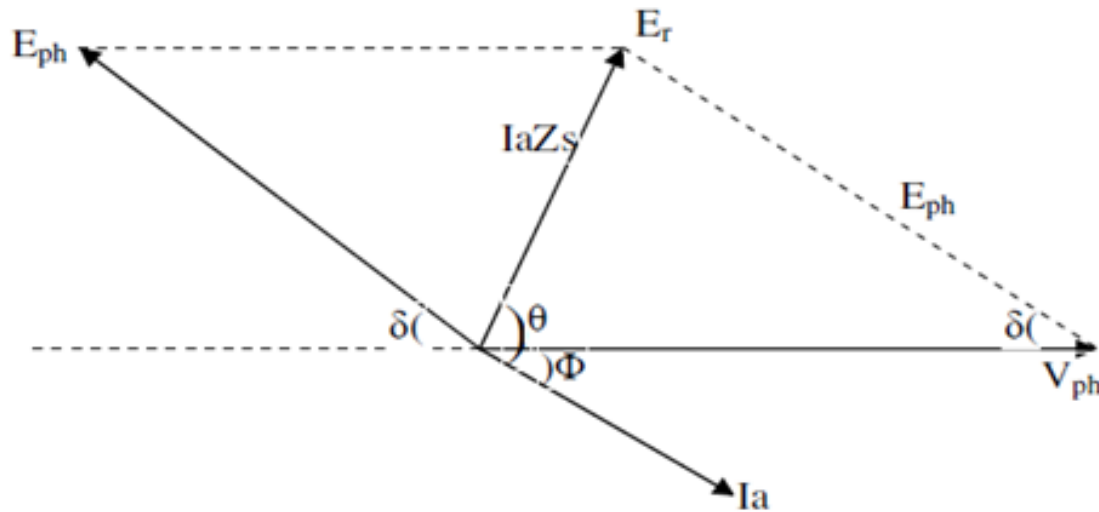

From the phasor diagram we can write Power input /phase $P_i = V_{ph} I_{ph} \cos\Phi$
 Mechanical power developed by the motor $P_m = E_b I_a \cos \angle E_b \& I_a = E_b I_a \cos(\delta - \Phi)$ Assuming iron losses as negligible stator cu losses = $P_i - P_m$
 Power output /phase = $P_m - (\text{field cu loss} + \text{friction \& windage loss} + \text{stray loss})$

Torque developed in Motor

- Mechanical power is given by $P_m = 2\pi N_s T_g / 60$ where N_s is the synchronous speed and the T_g is the gross torque developed.
- $P_m = 2\pi N_s T_g / 60$
- Hence $T_g = 60 P_m / 2\pi N_s$
- $T_g = 9.55 P_m / N_s$ N-m
- Shaft output torque $T_{sh} = 60 \times P_{out} / 2\pi N_s$
- $T_{sh} = 9.55 P_{out} / N_s$ N-m

Numerical problems

- A 75 KW 3phase Y connected, 50 Hz, 440V cylindrical rotor synchronous motor operates at rated condition with 0.8pf leading. The motor efficiency excluding field and stator losses, is 95% and $X_s=2.5\Omega$ calculate (i) mechanical power developed (ii) armature current (iii) back EMF (iv) power angle and (v)max or pull out toque of the motor.
- A 50 Hz, 6-pole, 3- Φ , and star-connected synchronous motor has a synchronous reactance of 12.2Ω /phase and negligible armature resistance. The excitation is such as to give an open-circuit voltage of 13.4kv.the motor is connected to 11.9KV, 50 Hz supply. What maximum load can the motor supply before losing synchronism? What is the corresponding motor torque, line current and power factor?

- A 50 Hz, 8-pole, 3- Φ , and star-connected synchronous motor has a synchronous reactance of 10Ω /phase and negligible armature resistance. The excitation is such as to give an open-circuit voltage of 14 KV the motor is connected to 12.5 KV, 50 Hz supply. What maximum load can the motor supply before losing synchronism? What is the corresponding motor torque, line current and power factor?

V and inverted V curve of synchronous motor

- Graphs of armature current vs. field current of synchronous motors are called V curves and are shown in Figure below for typical values of synchronous motor loads. The curves are related to the phasor diagram shown in figure below, and illustrate the effect of the variation of field excitation on armature current and power factor. It can be easily noted from these curves that an increase in shaft loads require an increase in field excitation in order to maintain the power factor at unity.
- The points marked *a*, *b*, and *c* on the upper curve corresponds to the operating conditions of the phasor diagrams shown. Note that for $P = 0$, the lagging power factor operation is electrically equivalent to an inductor and the leading power factor operation is electrically equivalent to a capacitor. Leading power factor operation with $P = 0$ is sometimes referred to as synchronous condenser or synchronous capacitor operation. Typically, the synchronous machine V-curves are provided by the manufacturer so that the user can determine the resulting operation under a given set of conditions.

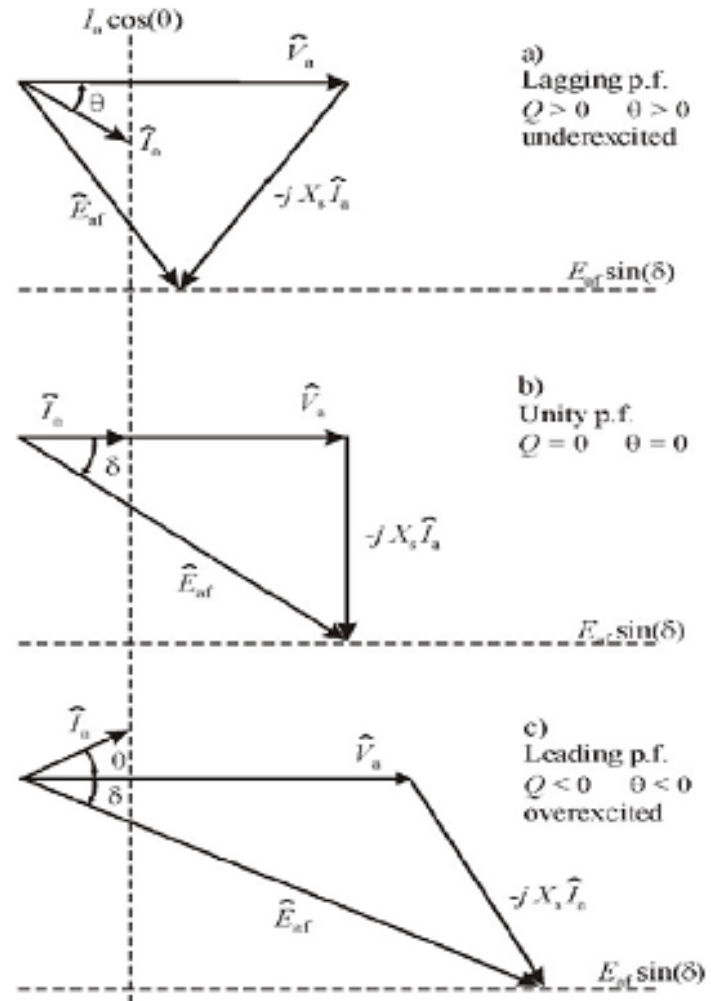
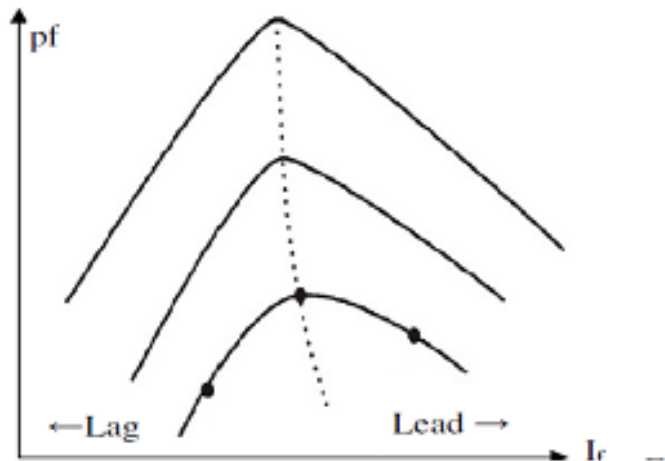
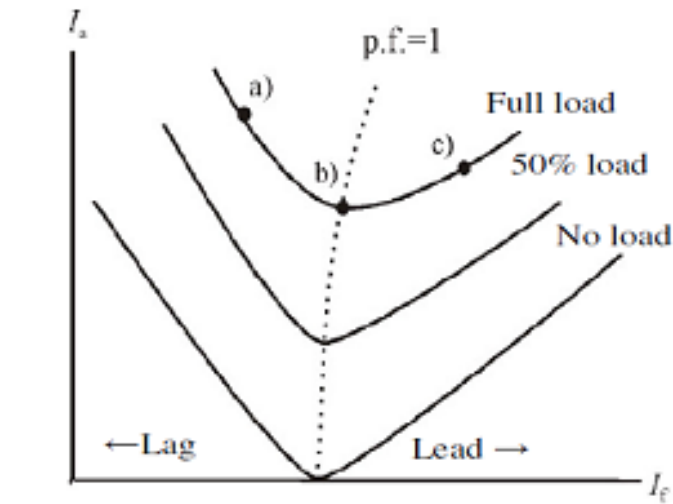

Numerical problems

- The excitation of a 415V, 3-phase, and mesh connected synchronous motor is such that the induced EMF is 520 V. the impedance per phase is $(0.5+j4.0) \Omega$. If the friction and iron losses are constant at 1000watts, calculate the power output, line current, power factor and efficiency for maximum power output?
- The excitation of a 415 V, 3-phase, and mesh connected synchronous motor is such that the induced EMF is 520V. the impedance per phase is $(0.5+j4.0) \Omega$. If the friction and iron losses are constant at 1000watts, calculate the power output, line current, power factor and efficiency for maximum power output?

- The excitation of a 415V, 3-phase, and mesh connected synchronous motor is such that the induced EMF is 520V. The impedance per phase is $(0.85 + j6.0) \Omega$. If the friction and iron losses are constant at 800 watts, calculate the power output, line current, power factor and efficiency for maximum power output?

- Sudden changes of load on synchronous motors may sometimes set up oscillations that are superimposed upon the normal rotation, resulting in periodic variations of a very low frequency in speed. This effect is known as hunting or phase-swinging. Occasionally, the trouble is aggravated by the motor having a natural period of oscillation approximately equal to the hunting period. When the synchronous motor phase-swings into the unstable region, the motor may fall out of synchronism

Damper winding

- The tendency of hunting can be minimized by the use of a damper winding. Damper windings are placed in the pole faces. No EMFs are induced in the damper bars and no current flows in the damper winding, which is not operative.
- Whenever any irregularity takes place in the speed of rotation, however, the polar flux moves from side to side of the pole, this movement causing the flux to move backwards and forwards across the damper bars. EMFs are induced in the damper bars forwards across the damper winding.
- These tend to damp out the superimposed oscillatory motion by absorbing its energy. The damper winding, thus, has no effect upon the normal average speed, it merely tends to damp out the oscillations in the speed, acting as a kind of electrical flywheel. In the case of a three-phase synchronous motor the stator currents set up a rotating MMF rotating at uniform speed and if the rotor is rotating at uniform speed, no EMFs are induced in the damper bars.

Synchronous condenser

- An over excited synchronous motor operates at unity or leading power factor. Generally, in large industrial plants the load power factor will be lagging. The specially designed synchronous motor running at zero load, taking leading current, approximately equal to 90° . When it is connected in parallel with inductive loads to improve power factor, it is known as synchronous condenser. Compared to static capacitor the power factor can improve easily by variation of field excitation of motor. Phasor diagram of a synchronous condenser connected in parallel with an inductive load is given below.

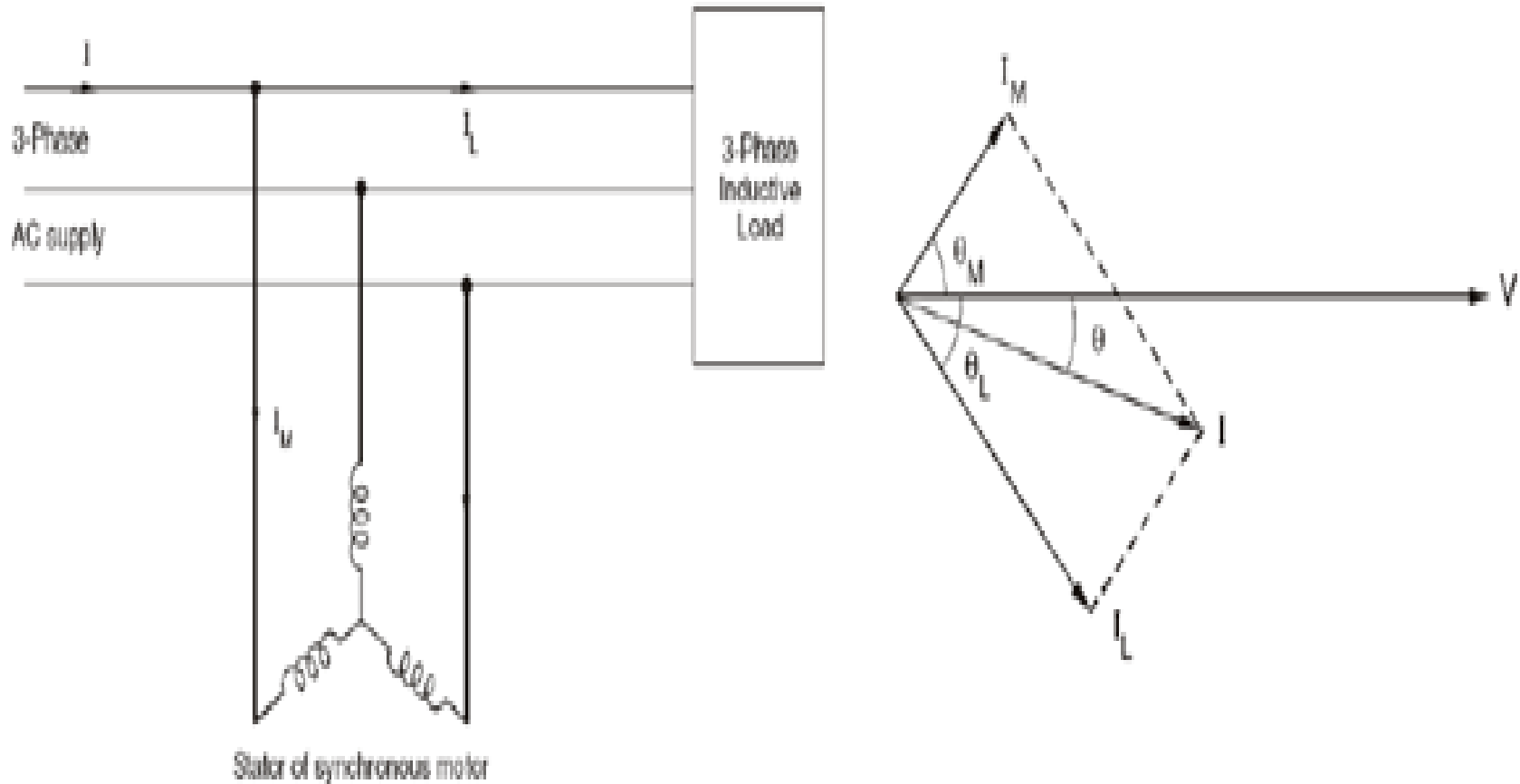

Figure:53 Synchronous condenser and phasor diagram

Bolden's two reaction theory

- In case salient pole machines the air gap is non uniform and it is smaller along pole axis and is larger along the inter polar axis.
- These axes are called direct axis or d-axis and quadrature axis or q-axis. Hence the effect of MMF when acting along direct axis will be different than that when it is acting along quadrature axis.
- Hence the reactance of the stator cannot be same when the MMF is acting along d – axis and q- axis.

- As the length of the air gap is small along direct axis reluctance of the magnetic circuit is less and the air gap along the q – axis is larger and hence the along the quadrature axis will be comparatively higher.
- Hence along d-axis more flux is produced than q-axis. Therefore the reactance due to armature reaction will be different along d-axis and q-axis. This reactance's are
- X_{ad} = direct axis reactance; X_{aq} = quadrature axis reactance

- Blondel's two-reaction theory considers the effects of the quadrature and direct-axis components of the armature reaction separately.
- Neglecting saturation, their different effects are considered by assigning to each an appropriate value of armature-reaction "reactance," respectively X_{aq} and X_{dq} .
- The effects of armature resistance and true leakage reactance (X_L) may be treated separately, or may be added to the armature reaction coefficients on the assumption that they are the same, for either the direct-axis or quadrature-axis components of the armature current

- Thus the combined reactance values can be expressed as:

$X_{sd} = X_{aq} + X_L$ and $X_{aq} = X_{aq} + X_L$ for the direct- and cross-reaction axes respectively.

- In a salient-pole machine, X_{aq} , the quadrature-axis reactance is smaller than X_{ad} , the direct-axis reactance, since the flux produced by a given current component in that axis is smaller as the reluctance of the magnetic path consists mostly of the inter polar spaces.
- It is essential to clearly note the difference between the quadrature and direct-axis components I_{aq} , and I_{ad} of the armature current I_a , and the reactive and active components I_{aa} and I_{ar} .

Phasor diagrams

(a) Components of I_a

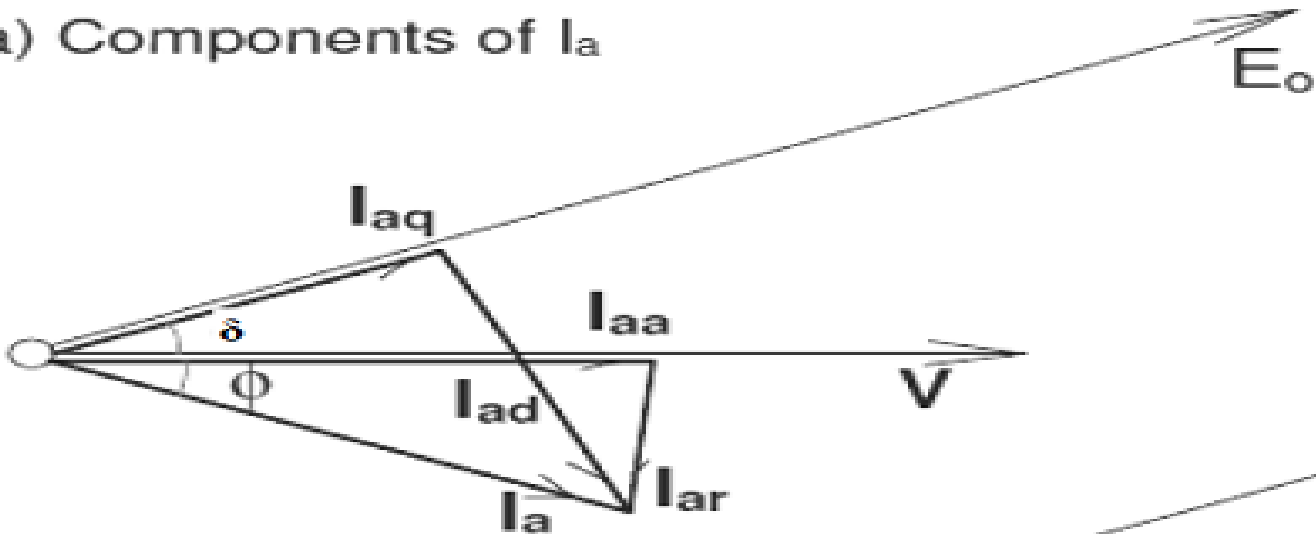

(b) Phasor addition of component drops

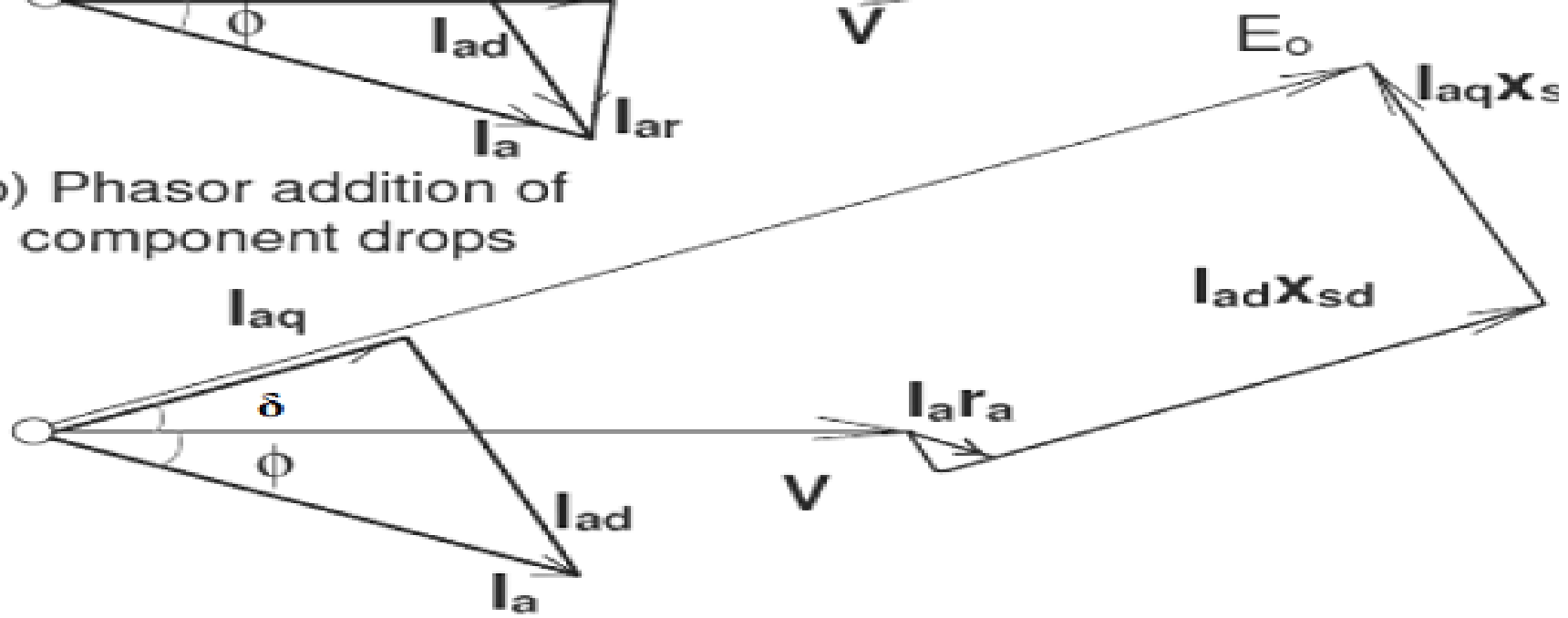

Figure: 3.5. Phasor diagram of salient pole alternator

Slip test

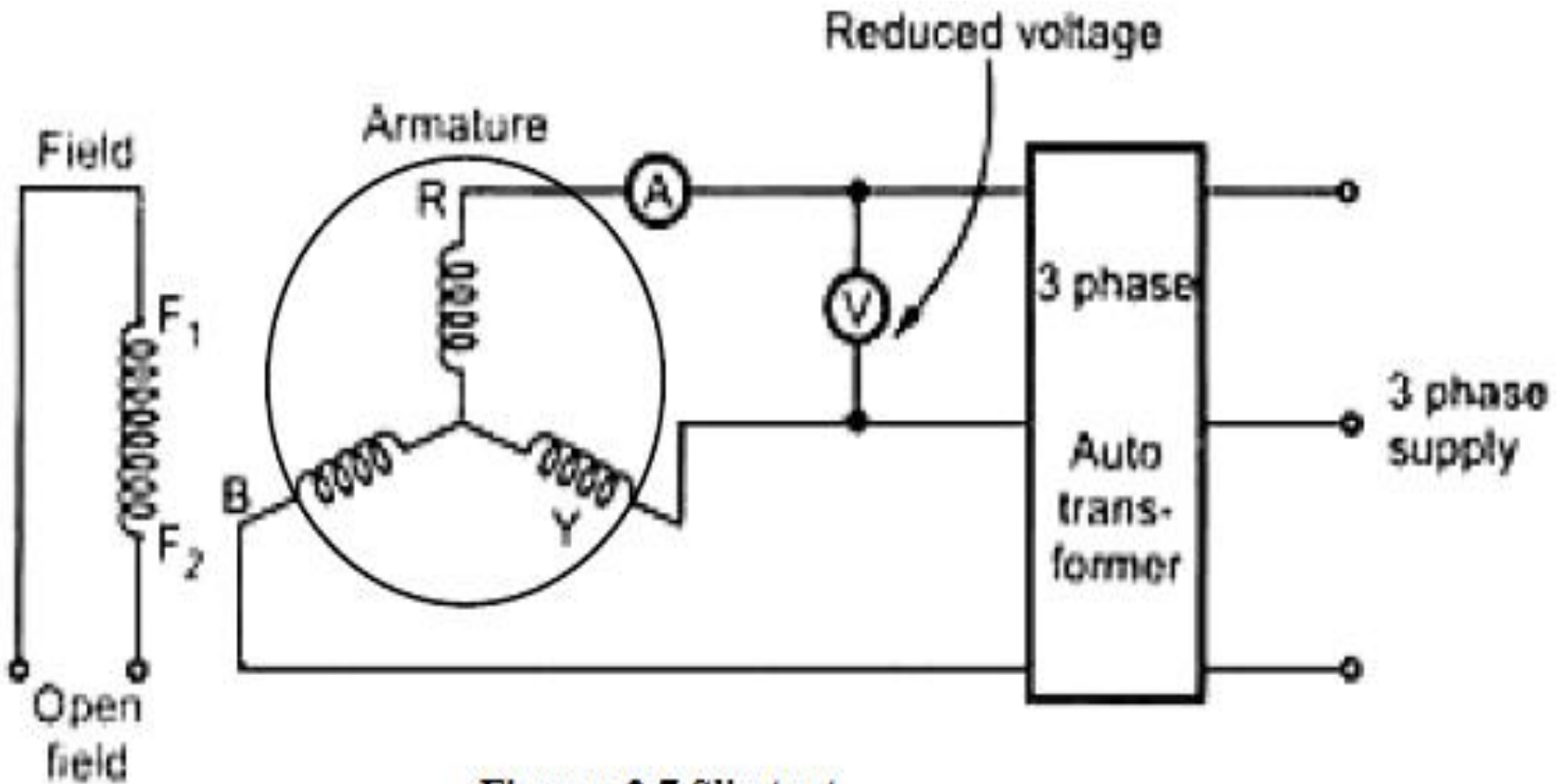

Figure: 3.7 Slip test



MODULE - V

SINGLE PHASE INDUCTION

MOTOR

Single phase induction motor Principle of operation

- The single phase induction motor in its simplest form is structurally the same as a poly- phase induction motor having a squirrel cage rotor, the only difference is that the single phase induction motor has single winding on the stator which produces MMF stationary in space but alternating in time, a poly phase stator winding carrying balanced currents produces MMF rotating in space around the air gap and constant in time with respect to an observer moving with the MMF. The stator winding of the single phase motor is disposed in slots around the inner periphery of a laminated ring similar to the 3-phase motor.

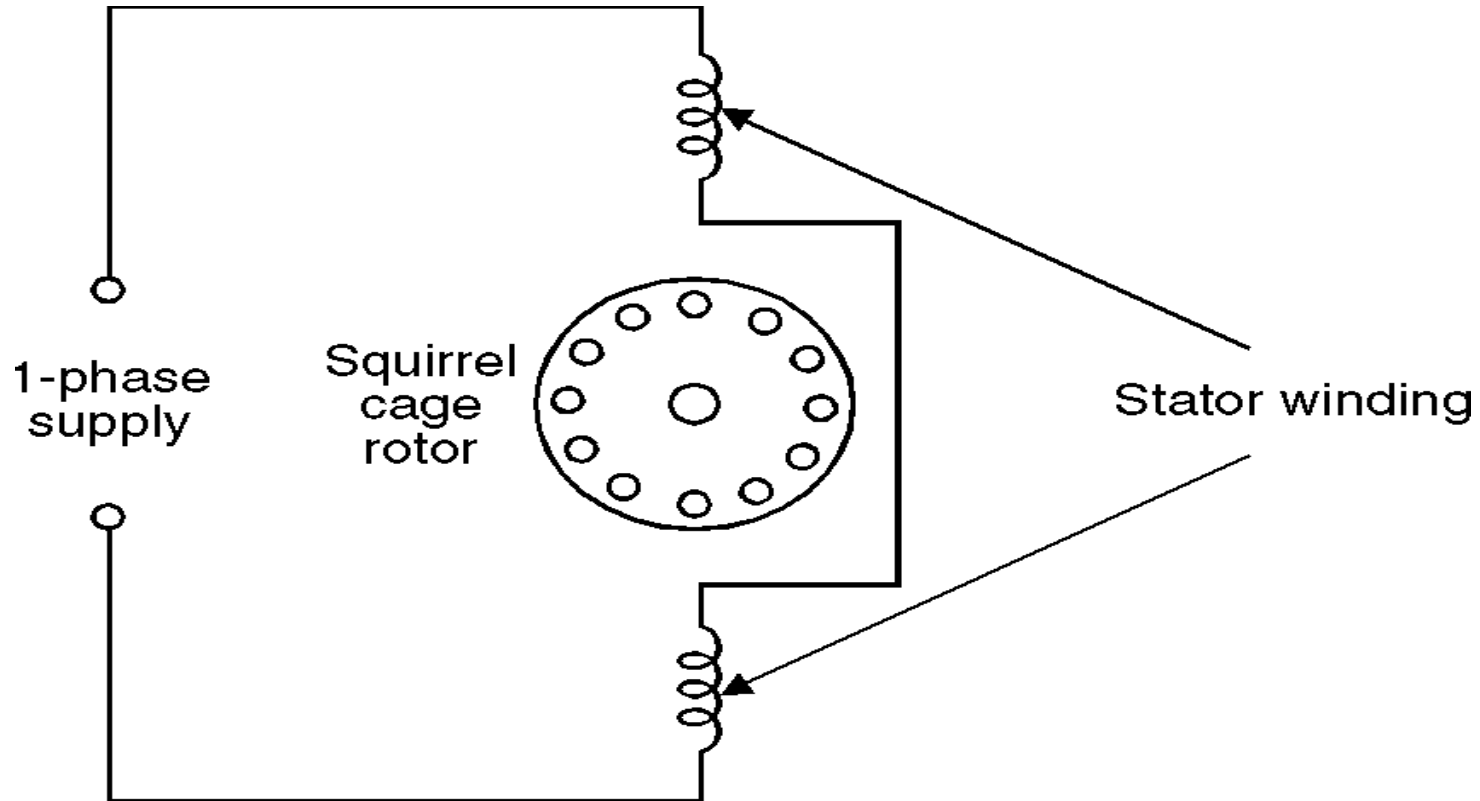

Figure: 54. Elementary single phase induction motor

- Suppose the rotor is at rest and 1-phase supply is given to stator winding. The current flowing in the stator winding gives rise to an MMF whose axis is along the winding and it is a pulsating MMF, stationary in space and varying in magnitude, as a function of time, varying from positive maximum to zero to negative maximum and this pulsating MMF induces currents in the short-circuited rotor of the motor which gives rise to an MMF. The currents in the rotor are induced due to transformer action and the direction of the currents is such that the MMF so developed opposes the stator MMF. The axis of the rotor MMF is same as that of the stator MMF. Since the torque developed is proportional to sine of the angle between the two MMF and since the angle is zero, the net torque acting on the rotor is zero and hence the rotor remains stationary.

- For analytical purposes a pulsating field can be resolved into two revolving fields of constant magnitude and rotating in opposite directions as shown in Fig. 55 and each field has a magnitude equal to half the maximum length of the original pulsating phasor.

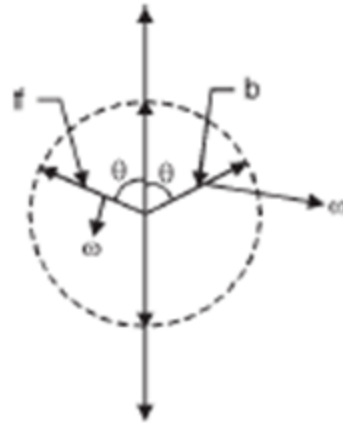

Figure: 55. Representation of the pulsating field by space phasor

- The resultant torque-speed characteristic which is the algebraic sum of the two component curves shows that if the motor were started by auxiliary means it would produce torque in whatever direction it was started.

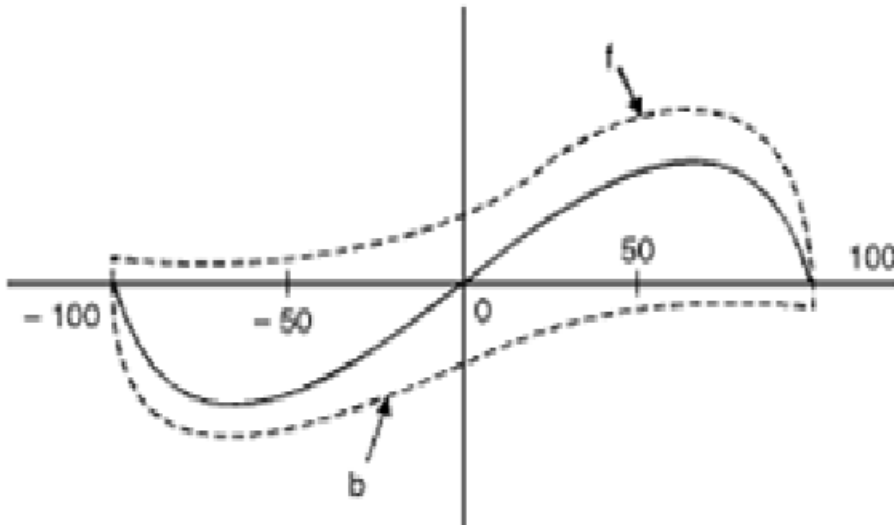

Figure: 56. Torque-speed characteristic of a 1-phase induction motor based on constant forward and backward flux waves.