

Brushless-DC Motor 1: Basics

TI Precision Labs – Motor Drivers

Presented and Prepared by Sanmeshkumar Udhayakumar



Easy model of BLDC motor

Permanent magnet rotor

Stationary coils on stator

Moving magnetic field
continuously drags the rotor
along the circle

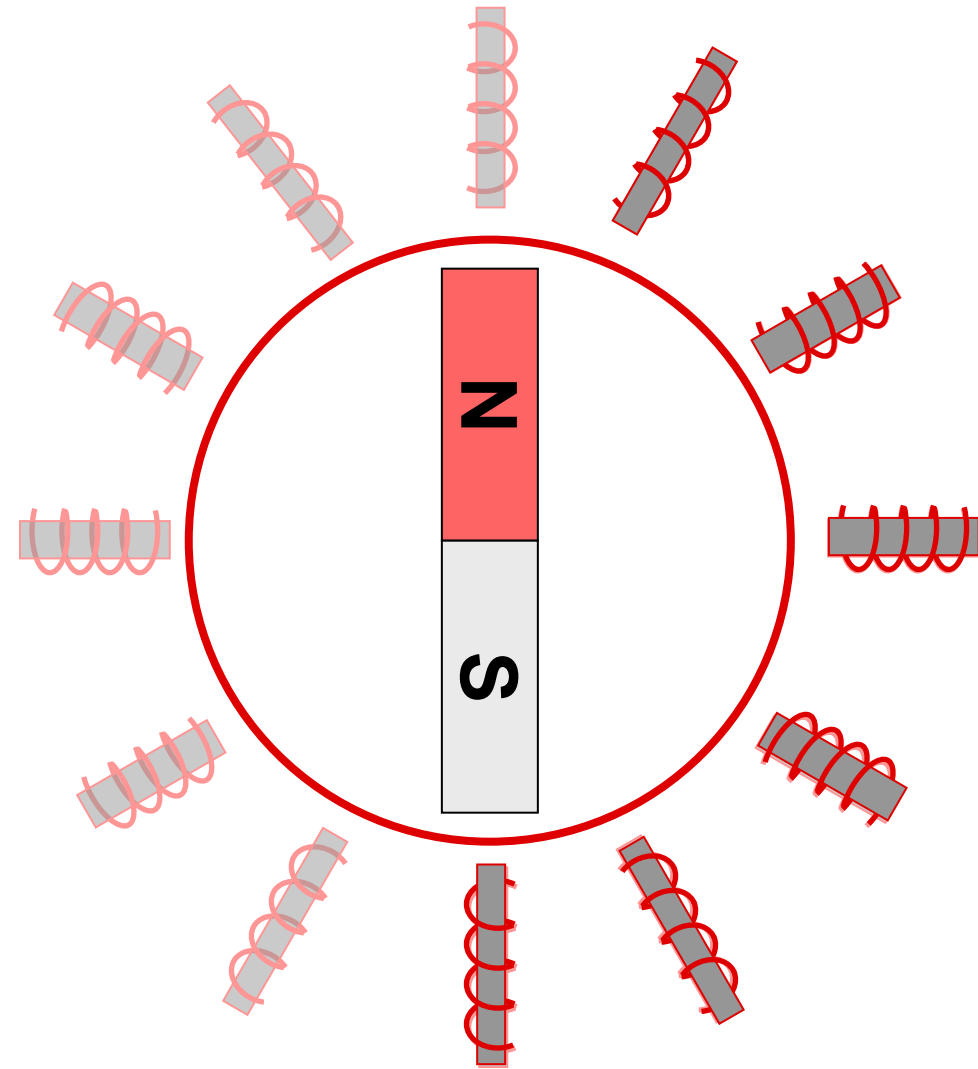

BLDC commutation

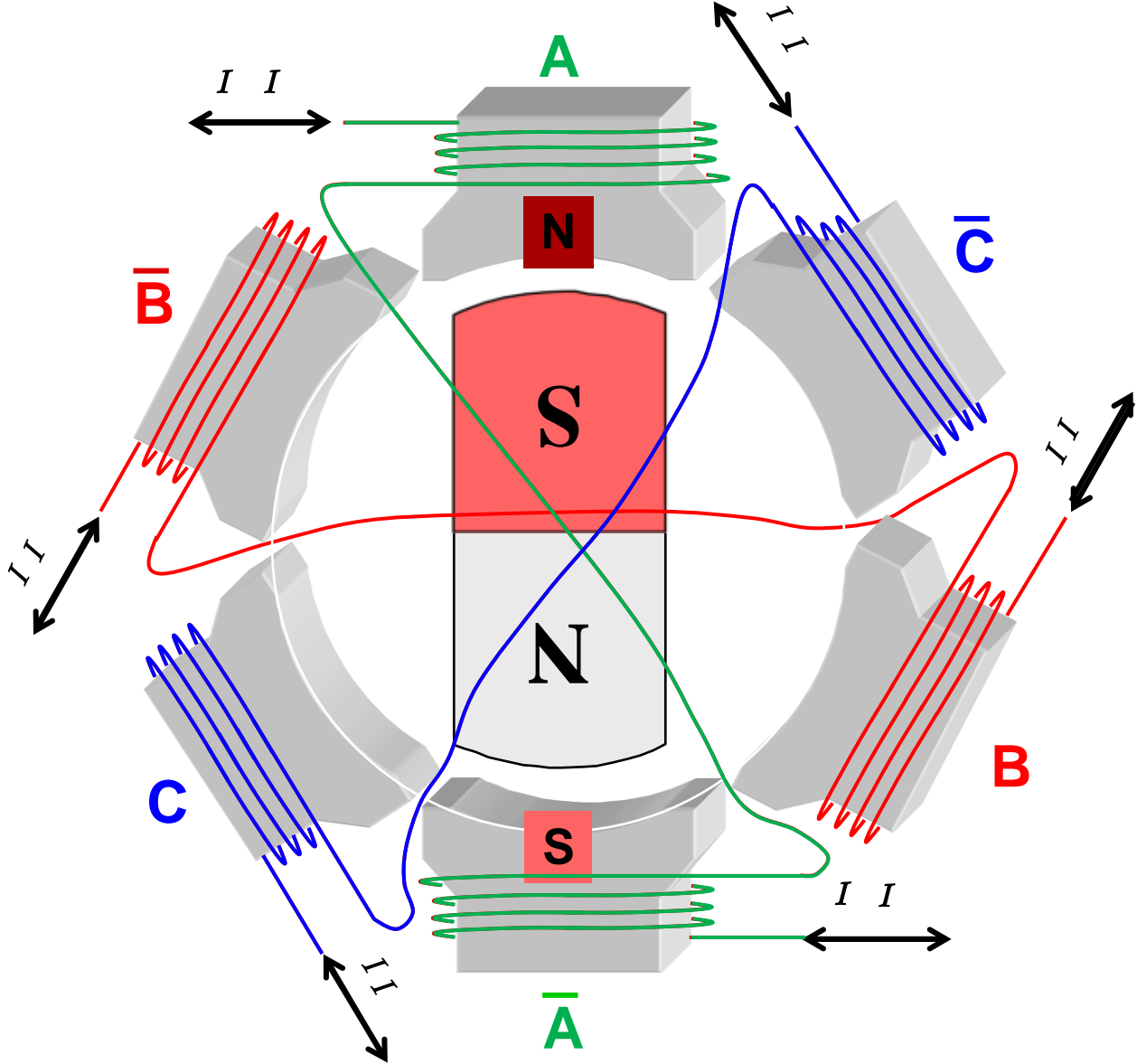

Brushed vs brushless DC motor

Brushed-DC motor

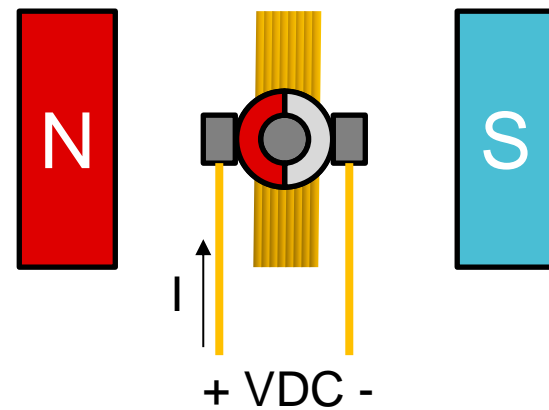

Commutation automatically handled by mechanical design

Brushless-DC motor

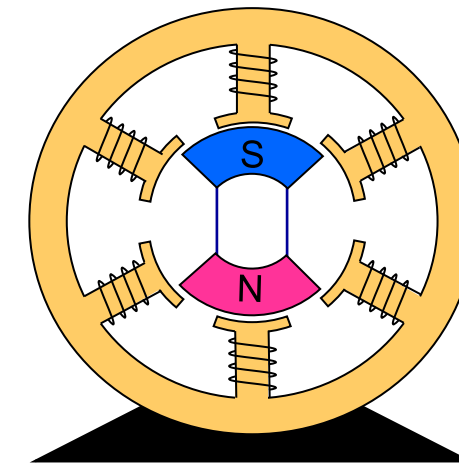

Motor driver circuitry needs to handle commutation

Motor winding configuration

**Wye (Y) winding
star connection**

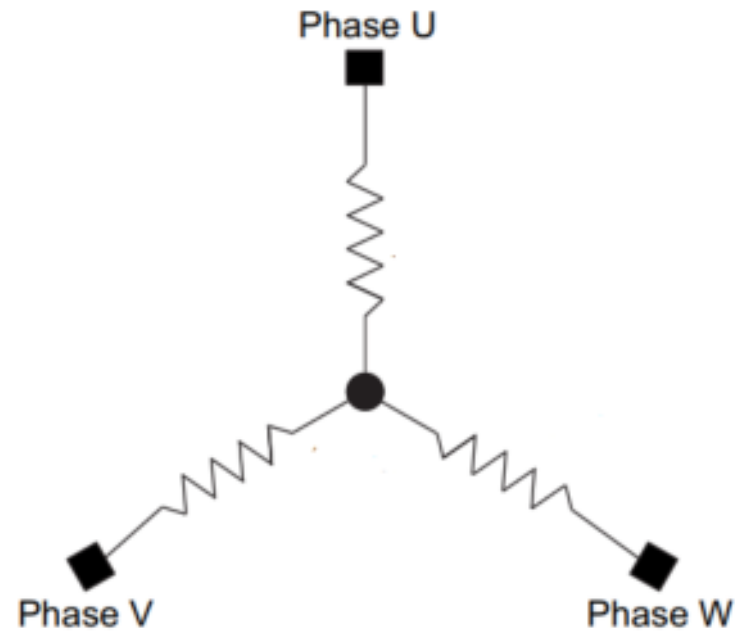

Delta (Δ) winding connection

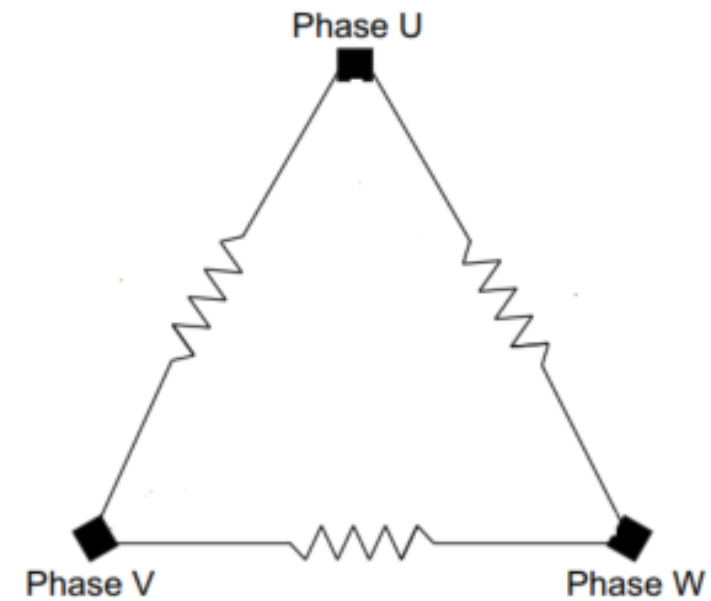

Both are driven the same way

Sinusoidal vs trapezoidal back-electromotive force (BEMF)

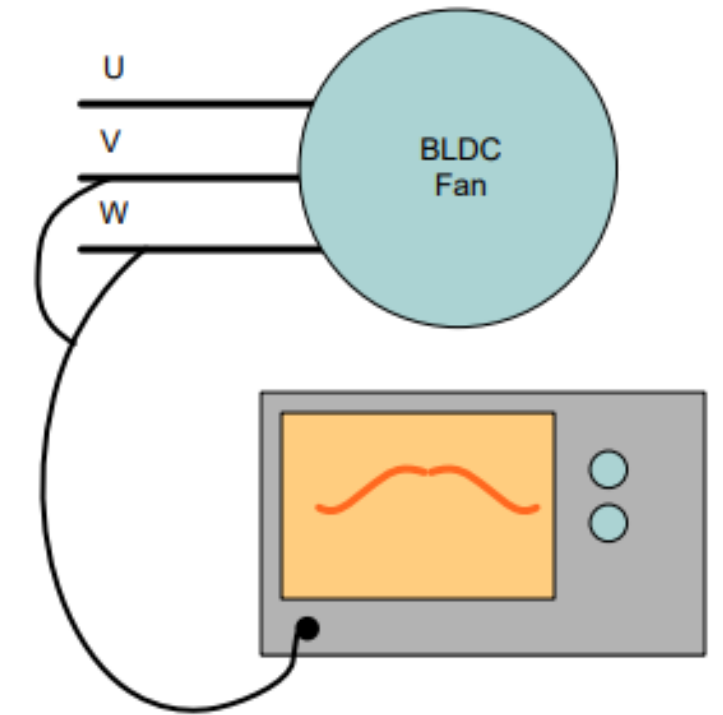
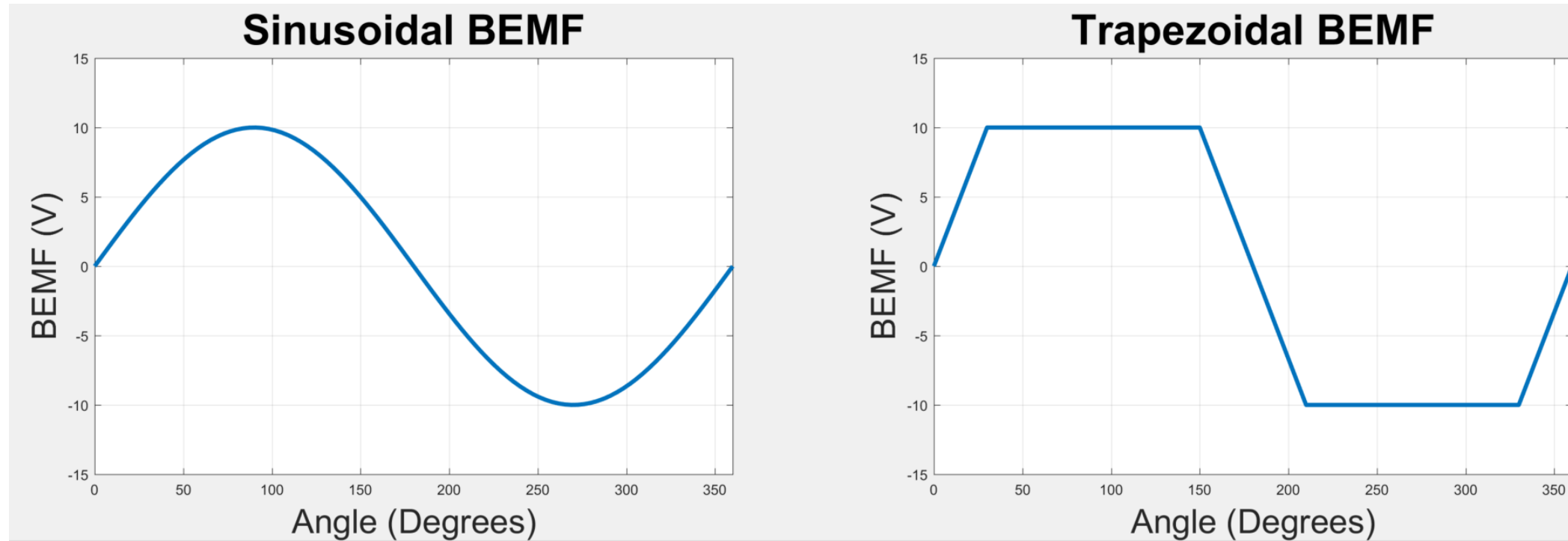

Electrical vs mechanical cycle

- Mechanical cycle:
Time for the motor to travel one full revolution
- Electrical cycle:
Time for the rotor to pass a pair of poles.

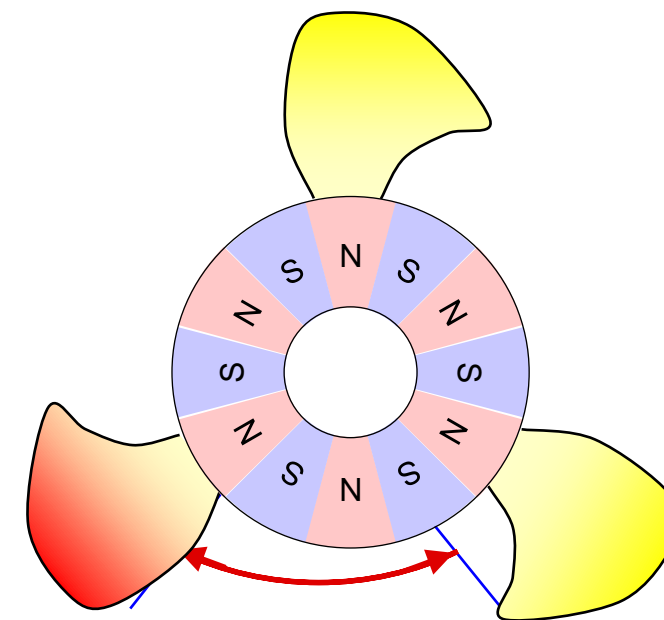

$$\text{mechanical speed} = \frac{\text{electrical speed}}{\# \text{ of pole pairs}}$$

Motor control circuitry

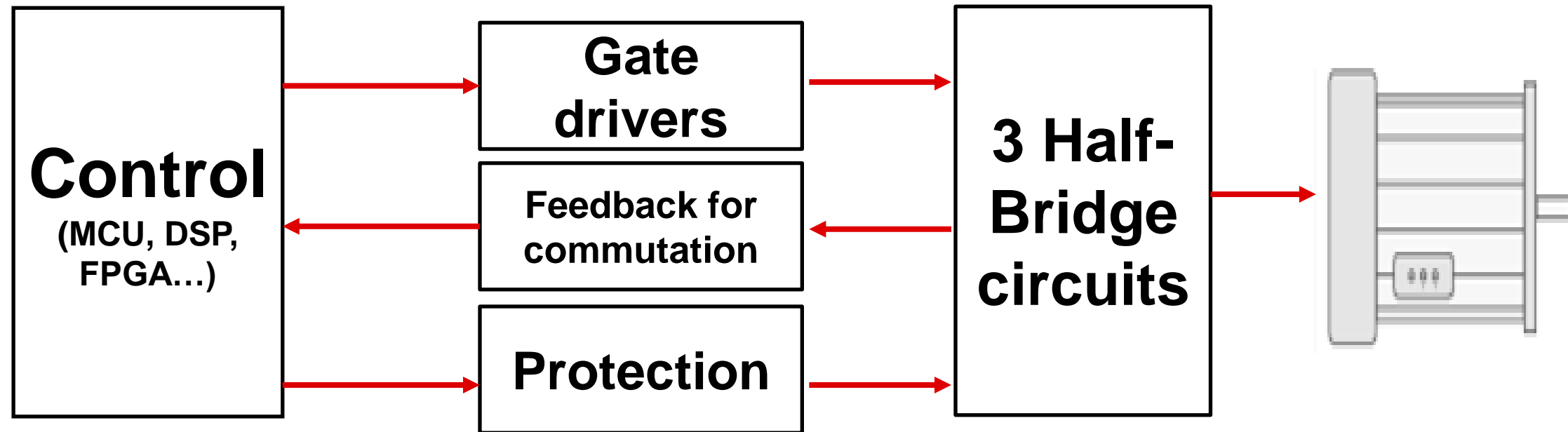

3 Half-Bridge circuits and gate drivers

- 3 Half-bridge circuits indicated by dotted boxes
- Half-bridge circuits connect motor phases to Vcc or GND
- Gate drivers turn on/off MOSFETs in half-bridge circuits to connect to Vcc or GND

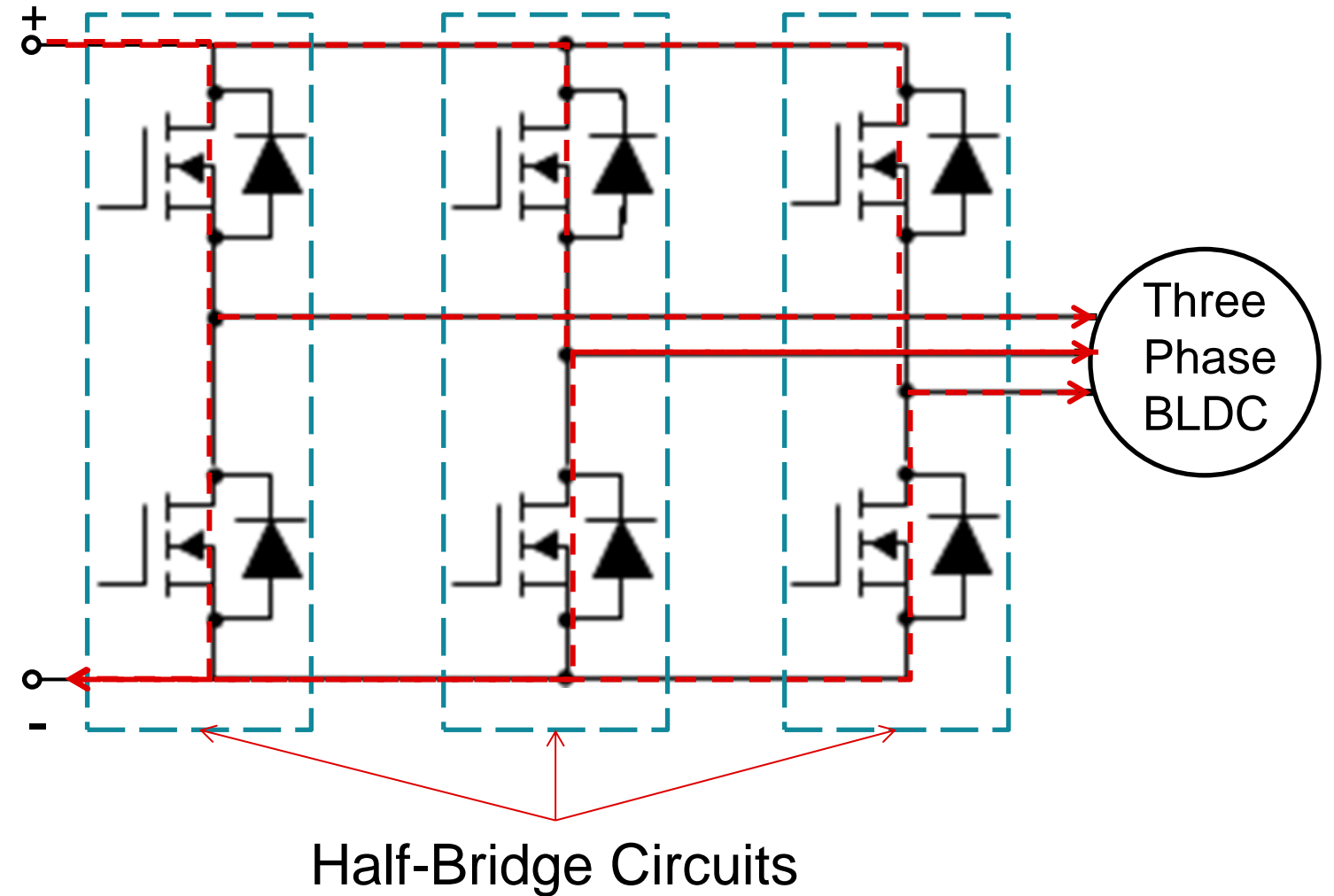
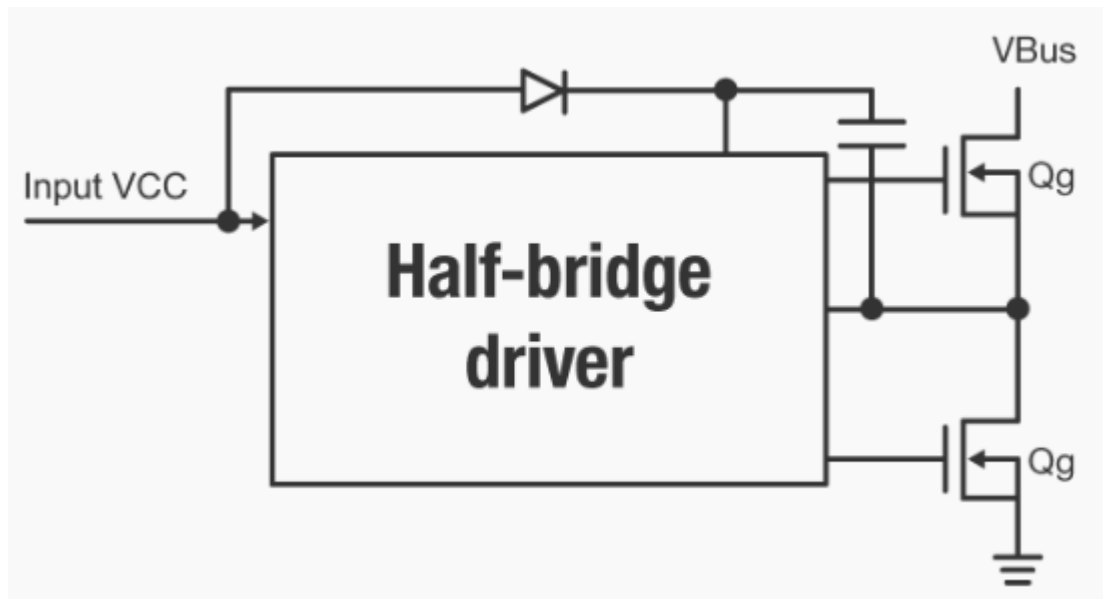

Control Block

- Control block: Controls gate drivers to dictate commutation through the half-bridge circuits
 - MCU
 - FPGA
 - DSP
 - Digital state machine
 - Pure analog implementation

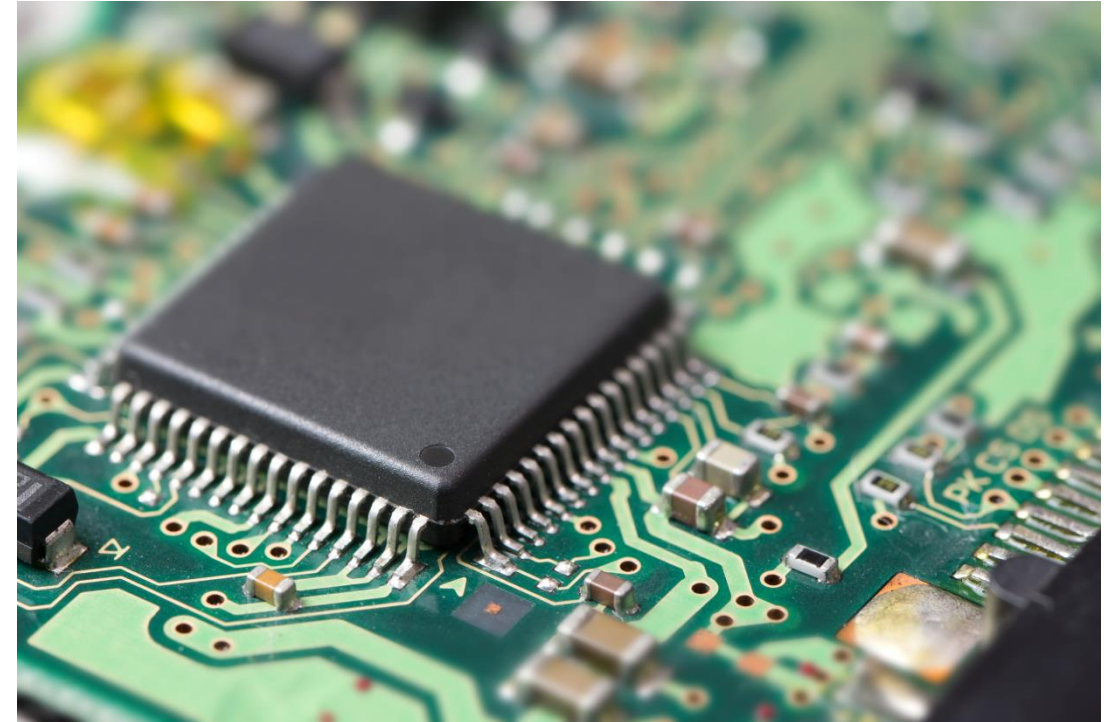

Feedback for Commutation

- Feedback of rotor position for commutation:
 - Encoders
 - Hall-effect
 - BEMF

Encoder

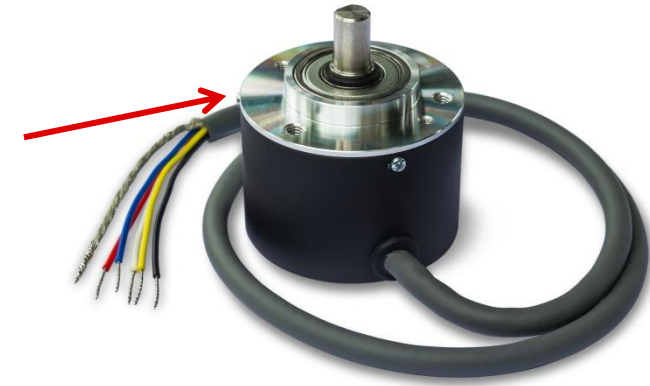

Hall-Effect Sensors

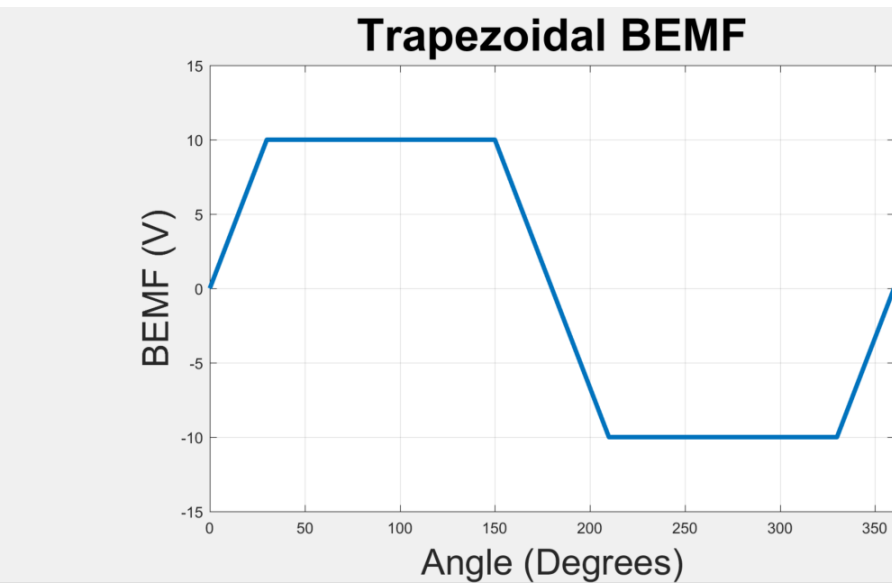
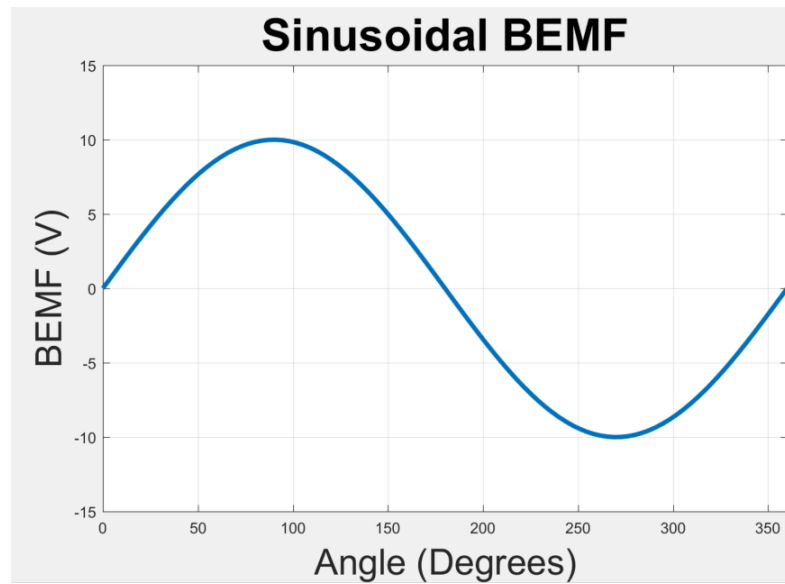

Motor Circuitry Protection

**Over current
protection (OCP)**

Thermal shutdown

**Under-Voltage
lock-out
(UVLO)**

Shoot-Through

Lock detect

**Anti-Voltage surge
(AVS)**

To find more motor driver technical resources and search products, visit [ti.com/motordrivers](https://www.ti.com/motordrivers)